

TOSHIBA

FILE NO. 050-200407

SERVICE MANUAL

COLOR TELEVISION

27AFX54

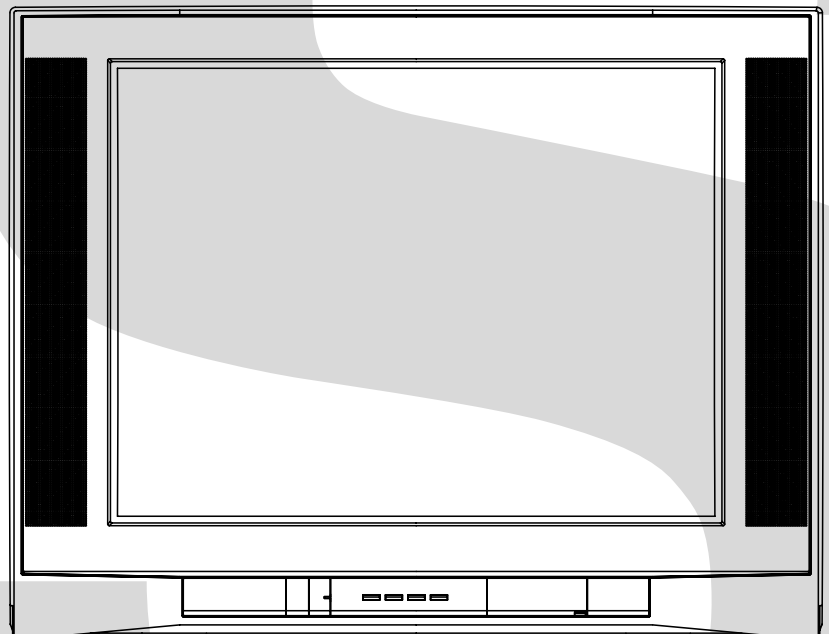

SERVICING NOTICES ON CHECKING

1. KEEP THE NOTICES

As for the places which need special attentions, they are indicated with the labels or seals on the cabinet, chassis and parts. Make sure to keep the indications and notices in the operation manual.

2. AVOID AN ELECTRIC SHOCK

There is a high voltage part inside. Avoid an electric shock while the electric current is flowing.

3. USE THE DESIGNATED PARTS

The parts in this equipment have the specific characters of incombustibility and withstand voltage for safety. Therefore, the part which is replaced should be used the part which has the same character.

Especially as to the important parts for safety which is indicated in the circuit diagram or the table of parts as a  mark, the designated parts must be used.

4. PUT PARTS AND WIRES IN THE ORIGINAL POSITION AFTER ASSEMBLING OR WIRING

There are parts which use the insulation material such as a tube or tape for safety, or which are assembled in the condition that these do not contact with the printed board. The inside wiring is designed not to get closer to the pyrogenic parts and high voltage parts. Therefore, put these parts in the original positions.

5. TAKE CARE TO DEAL WITH THE CATHODE-RAY TUBE

In the condition that an explosion-proof cathode-ray tube is set in this equipment, safety is secured against implosion. However, when removing it or serving from backward, it is dangerous to give a shock. Take enough care to deal with it.

6. AVOID AN X-RAY

Safety is secured against an X-ray by considering about the cathode-ray tube and the high voltage peripheral circuit, etc.

Therefore, when repairing the high voltage peripheral circuit, use the designated parts and make sure not modify the circuit.

Repairing except indicates causes rising of high voltage, and it emits an X-ray from the cathode-ray tube.

7. PERFORM A SAFETY CHECK AFTER SERVICING

Confirm that the screws, parts and wiring which were removed in order to service are put in the original positions, or whether there are the portions which are deteriorated around the serviced places serviced or not. Check the insulation between the antenna terminal or external metal and the AC cord plug blades. And be sure the safety of that.

(INSULATION CHECK PROCEDURE)

1. Unplug the plug from the AC outlet.
2. Remove the antenna terminal on TV and turn on the TV.
3. Insulation resistance between the cord plug terminals and the external exposure metal **[Note 2]** should be more than 1M ohm by using the 500V insulation resistance meter **[Note 1]**.
4. If the insulation resistance is less than 1M ohm, the inspection repair should be required.

[Note 1]

If you have not the 500V insulation resistance meter, use a Tester.

[Note 2]

External exposure metal: Antenna terminal

HOW TO ORDER PARTS

Please include the following informations when you order parts. (Particularly the VERSION LETTER.)

1. MODEL NUMBER and VERSION LETTER

The MODEL NUMBER can be found on the back of each product and the VERSION LETTER can be found at the end of the SERIAL NUMBER.

2. PART NO. and DESCRIPTION

You can find it in your SERVICE MANUAL.

IMPORTANT

Inferior silicon grease can damage IC's and transistors.

When replacing an IC's or transistors, use only specified silicon grease (YG6260M).

Remove all old silicon before applying new silicon.



Licensed by BBE Sound, Inc. under USP4638258, 5510752 and 5736897.

BBE and BBE symbol are registered trademarks of BBE Sound, Inc.

TABLE OF CONTENTS

SERVICING NOTICES ON CHECKING	A1-1
HOW TO ORDER PARTS	A1-1
IMPORTANT	A1-1
TABLE OF CONTENTS	A2-1
GENERAL SPECIFICATIONS	A3-1~A3-5
DISASSEMBLY INSTRUCTIONS	
1. REMOVAL OF ANODE CAP	B1-1
2. REMOVAL AND INSTALLATION OF FLAT PACKAGE IC	B2-1, B2-2
SERVICE MODE LIST	C1-1
CONFIRMATION OF HOURS USED	C1-1
WHEN REPLACING EEPROM (MEMORY) IC	C1-1
ELECTRICAL ADJUSTMENTS	D-1~D-6
BLOCK DIAGRAM	E-1, E-2
PRINTED CIRCUIT BOARDS	
MAIN	F-1~F-4
CRT/VM COIL/COMB	F-5, F-6
SCHEMATIC DIAGRAMS	
MICON	G-1, G-2
CHROMA	G-3, G-4
DEFLECTION/CRT	G-5, G-6
POWER	G-7, G-8
SOUND	G-9, G-10
TUNER/STEREO	G-11, G-12
AV	G-13, G-14
REGULATOR	G-15, G-16
CRT/SVM	G-17, G-18
COMB/FILTER	G-19, G-20
WAVEFORMS	H-1, H-2
MECHANICAL EXPLODED VIEWS	I-1, I-2
MECHANICAL REPLACEMENT PARTS LIST	J1-1
ELECTRICAL REPLACEMENT PARTS LIST	J2-1~J2-6

GENERAL SPECIFICATIONS

G-1	TV System	CRT	CRT Size / Visual Size	27 inch / 676.6mmV	
			CRT Type	Flat	
			Deflection	104 degree	
			Magnetic Field BV/BH	+0.45G/0.18G	
			Color System	NTSC	
			Speaker	2 Speaker	
				Position	Front Side
				Size	1.8 x 3.9 Inch
				Impedance	8 ohm
			Sound Output	MAX	5.0+5.0 W
		10%(Typical)	4.0+4.0 W		
		NTSC3.58+4.43 /PAL60Hz	No		
G-2	Tuning System	Broadcasting System		US System M	
		Tuner and Receive CH	System	1Tuner	
			Destination	USA(W/ CATV)	
			Tuning System	F-Synth	
			Input Impedance	VHF/UHF 75 ohm	
				CH Coverage	2 - 69, 4A, A-5 - A-1, A - I, J - W, W+1 - W+84
			Intermediate Frequency	Picture(FP)	45.75MHz
				Sound(FS)	41.25MHz
				FP-FS	4.50MHz
			Preset CH		No
G-3	Power	Power Source	AC	120V AC 60Hz	
			DC		
		Power Consumption		at AC	
			Stand by (at AC)		135 W at AC 120 V 60 Hz
			Per Year		3 W at AC 120 V 60 Hz
			-- kWh/Year		
	Protector	Power Fuse		Yes	
G-4	Regulation	Safety		UL/CSA	
		Radiation		FCC/IC	
		X-Radiation		DHHS/HWC	
G-5	Temperature	Operation		+5oC ~ +40oC	
		Storage		-20oC ~ +60oC	
G-6	Operating Humidity			Less than 80% RH	

GENERAL SPECIFICATIONS

G-7	On Screen Display	Menu		Yes
		Menu Type		Icon
		Picture		Yes
		Contrast		Yes
		Brightness		Yes
		Color		Yes
		Tint		Yes
		Sharpness		Yes
		Reset		Yes
		Sound		Yes
		Bass		Yes
		Treble		Yes
		Balance		Yes
		MTS		Yes
		BBE On/Off		Yes
		Stable Sound On/Off		Yes
		Surround On/Off		Yes
		Set Up		Yes
		Closed Caption		Yes
		PIP Source		No
		TV/CATV		Yes
		Auto CH Memory		Yes
		Add/ Delete		Yes
		Mode		Yes
		Color Temperature		Yes
		Picture Preference		Yes
		Option		Yes
		Language		Yes
		CH Label		Yes
		Favorite CH		Yes
		V-Chip		Yes
		Lock		Yes
		On/Off Timer		Yes
		Color Stream DVD/DTV		Yes
		Image Tilt		Yes
		Control Level		Yes
		Volume		Yes
		Brightness		Yes
		Contrast		Yes
		Color		Yes
Tint		Yes		
Sharpness		Yes		
Tuning		No		
Bass		Yes		
Treble		Yes		
Balance		Yes		
Image Tilt		Yes		
Stereo,Audio Output,SAP		Yes		
Video		Yes		
Color Stream		Yes		
Channel(TV/Cable)		Yes		
CH Label		Yes		
Game Timer		Yes		
Sleep Timer		Yes		
Sound Mute		Yes		
V-chip Rating		Yes		
16: 9		Yes		
G-8	OSD Language			English French Spanish
G-9	Clock and Timer	Sleep Timer	Max Time	120 Min
			Step	10 Min
		On/Off Timer	Program(On Timer / Off Timer)	Yes
		Wake Up Timer		No
	Timer Back-up (at Power Off Mode)	more than	--	Min Sec

GENERAL SPECIFICATIONS

G-10	Remote Control	Unit	RC-GR
		Glow in Dark Remocon	No
		Back Light Remocon	Yes
		Format	Toshiba
		Custom Code	TV:40-BFh
		Power Source	3V
		UM size x pcs	UM-3 x 2 pcs
		Total Keys	40 Keys
		Keys	Yes
		Power	Yes
		1	Yes
		2	Yes
		3	Yes
		4	Yes
		5	Yes
		6	Yes
		7	Yes
		8	Yes
		9	Yes
		0	Yes
		100 /+10	Yes
		CH Up	Yes
		CH Down	Yes
		Volume Up	Yes
		Volume Down	Yes
		TV/Video(Input Select)	Yes
		ENT,CH RTN(Quick View)	Yes
		Menu > / FAV Up	Yes
		Menu < / FAV Down	Yes
		Menu Up	Yes
		Menu Down	Yes
		Mute	Yes
		PIC SIZE (16:9)	Yes
		Light	Yes
		Multi Brand Keys	Yes
		(DVD Keys)	Yes
		(TV / DVD Keys)	Yes
		SLEEP/TOP MENU	Yes
		RECALL(Call) / (Display)	Yes
		Menu/Enter / DVD MENU	Yes
		Exit / DVD CLEAR	Yes
		(DVD / VCR Keys)	Yes
		Pause/Still	Yes
		FF	Yes
		Rew	Yes
		Play	Yes
		Stop	Yes
		<</Skip / Search Forward	Yes
		>>/Skip / Search Forward	Yes
		(VCR Keys)	Yes
		Rec	Yes
		TV/VCR	Yes

GENERAL SPECIFICATIONS

G-11	Features	Auto Degauss	Yes
		Auto Shut Off	Yes
		Canal+	No
		CATV	Yes
		Anti-theft	No
		Rental	No
		Memory(Last CH)	Yes
		Memory(Last Volume)	Yes
		V-Chip	Yes
		Type	USA, Toshiba Type
		BBE	Yes
		Auto Search	No
		CH Allocation	No
		SAP	Yes
		Just Clock Function	No
		CH Label	Yes
		VM Circuit	Yes
		Full OSD	No
		Premiere	No
		Comb Filter	Yes 3 -D
		Vertical Contour Correction	Yes
		Auto CH Memory	Yes
		Hotel Lock	No
		Closed Caption	Yes
		Stable Sound	Yes
		FBT Leak Test Protect	Yes
		CH Lock	Yes
		Video Lock	Yes
		Game Timer (Max Time:120 Min)	Yes
		Energy Star	No
		Favorite CH	Yes
		Surround	Yes
		16:9 Mode	Yes
		Color Temperature Control	Yes
		Picture Preference	Yes
		Tilt Correction	Yes
2 Tuner P-in-P	No		
G-12	Accessories	Owner's Manual	English / French
		Language W/ Warranty	Yes
		Remote Control Unit	Yes
		Rod Antenna	No
		Poles Terminal	
		Loop Antenna	No
		Terminal	-
		U/V Mixer	No
		DC Car Cord (Center+)	No
		Guarantee Card	No
		Warning Sheet	No
		Circuit Diagram	No
		Antenna Change Plug	No
		Service Station List	No
		Important Safety Instruction	No
		Dew/AHC Caution Sheet	No
		AC Plug Adapter	No
		Quick Set-up Sheet	No
		Battery	Yes UM-3 x 2
		UM size x pcs OEM Brand	No
		AC Cord	No
		AV Cord (2Pin-1Pin)	No
		Registration Card (NDL Card)	Yes
		PTB Sheet	No
		ESP Card	No[From '04 MAR O/R]
		300 ohm to 75 ohm Antenna Adapter	No

GENERAL SPECIFICATIONS

G-13	Interface	Switch	Front	Power	Yes	
				System Select	No	
				Main Power SW	No	
				Sub Power	No	
				Channel Up	Yes	
				Channel Down	Yes	
				Volume Up	Yes	
			Volume Down	Yes		
			Rear	AC/DC	No	
				TV/CATV Selector	No	
				Degauss	No	
			Main Power SW		No	
				Indicator	Power	Yes(RED)
					Stand-by	No
		Terminals	Front	Video Input = VIDEO3	RCA	
				Audio Input = VIDEO3	RCA x 2	
				S Input	Yes	
			Rear	Other Terminal	Head Phone	
				Video Input(Rear1) = VIDEO1	RCA	
				Video Input(Rear2) = VIDEO2	RCA	
				Audio Input(Rear1) = VIDEO1	RCA x 2	
				Audio Input(Rear2) = VIDEO2	RCA x 2	
				Video Output	RCA	
				Audio Output	RCA x 2	
				Euro Scart	No	
				Color Stream	RCA x 3	
				S Input	Yes	
				Diversity	No	
				Ext Speaker	No	
				DC Jack 12V(Center +)	No	
				VHF/UHF Antenna Input	F Type	
				AC Outlet	No	
G-14	Set Size	Approx. W x D x H (mm)		740 x 495 x 574.5		
G-15	Weight	Net (Approx.)		40.0 kg (88.2 lbs)		
		Gross (Approx.)		46.5kg (102.5lbs)		
G-16	Carton	Master Carton		No		
		Content		---- Sets		
		Material		-- /--		
		Dimensions W x D x H(mm)		-- x -- x --		
		Description of Origin		No		
		Gift Box		Yes		
		Material		Double/Brown		
		Dimensions W x D x H(mm)		850 x 620 x 665		
		Design		As per Buyer's		
		Description of Origin		Yes		
		Drop Test		Natural Dropping At 1 Corner / 2 Edges / 4 Surfaces		
		Height (cm)		40 (ORION SPEC:25)		
Container Stuffing		156 Sets/40' container				
G-17	Cabinet Material	Cabinet	Cabinet Front	PS 94V0 DECABROM		
			Cabinet Rear	PS 94V0 DECABROM		
		PCB	Non-Halogen Demand	No		
			Eyelet Demand	Yes		

DISASSEMBLY INSTRUCTIONS

1. REMOVAL OF ANODE CAP

Read the following **NOTED** items before starting work.

- * After turning the power off there might still be a potential voltage that is very dangerous. When removing the Anode Cap, make sure to discharge the Anode Cap's potential voltage.
- * Do not use pliers to loosen or tighten the Anode Cap terminal, this may cause the spring to be damaged.

REMOVAL

1. Follow the steps as follows to discharge the Anode Cap. (Refer to Fig. 1-1.)

Connect one end of an Alligator Clip to the metal part of a flat-blade screwdriver and the other end to ground. While holding the plastic part of the insulated Screwdriver, touch the support of the Anode with the tip of the Screwdriver. A cracking noise will be heard as the voltage is discharged.

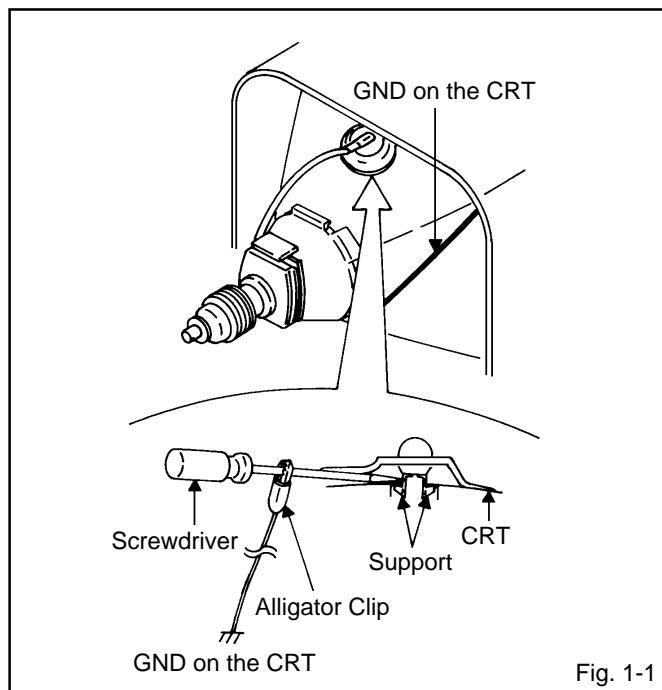

2. Flip up the sides of the Rubber Cap in the direction of the arrow and remove one side of the support. (Refer to Fig. 1-2.)

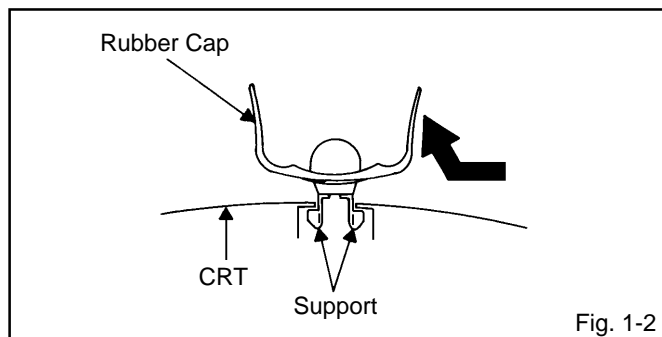

3. After one side is removed, pull in the opposite direction to remove the other.

NOTE

Take care not to damage the Rubber Cap.

INSTALLATION

1. Clean the spot where the cap was located with a small amount of alcohol. (Refer to Fig. 1-3.)

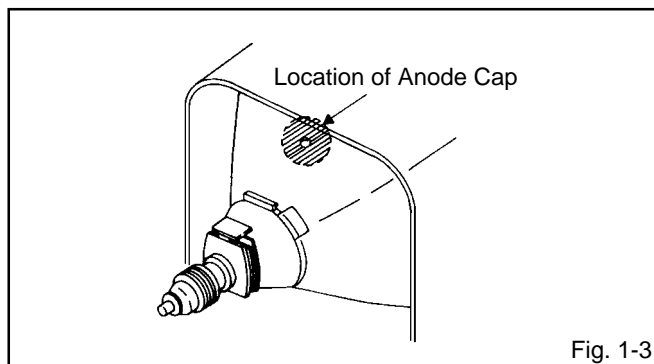

NOTE

Confirm that there is no dirt, dust, etc. at the spot where the cap was located.

2. Arrange the wire of the Anode Cap and make sure the wire is not twisted.
3. Turn over the Rubber Cap. (Refer to Fig. 1-4.)

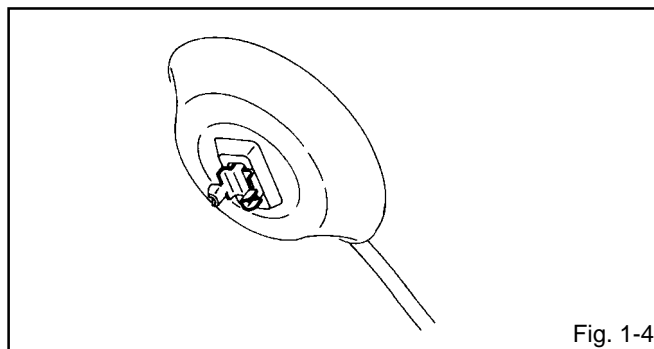

4. Insert one end of the Anode Support into the anode button, then the other as shown in Fig. 1-5.

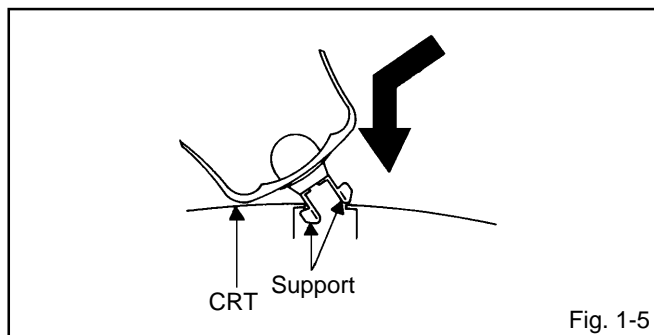

5. Confirm that the Support is securely connected.
6. Put on the Rubber Cap without moving any parts.

DISASSEMBLY INSTRUCTIONS

2. REMOVAL AND INSTALLATION OF FLAT PACKAGE IC

REMOVAL

1. Put the Masking Tape (cotton tape) around the Flat Package IC to protect other parts from any damage. (Refer to Fig. 2-1.)

NOTE

Masking is carried out on all the parts located within 10 mm distance from IC leads.

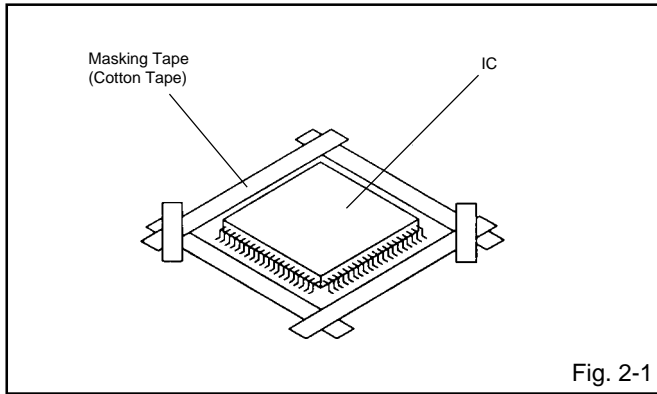

2. Heat the IC leads using a blower type IC desoldering machine. (Refer to Fig. 2-2.)

NOTE

Do not add the rotating and the back and forth directions force on the IC, until IC can move back and forth easily after desoldering the IC leads completely.

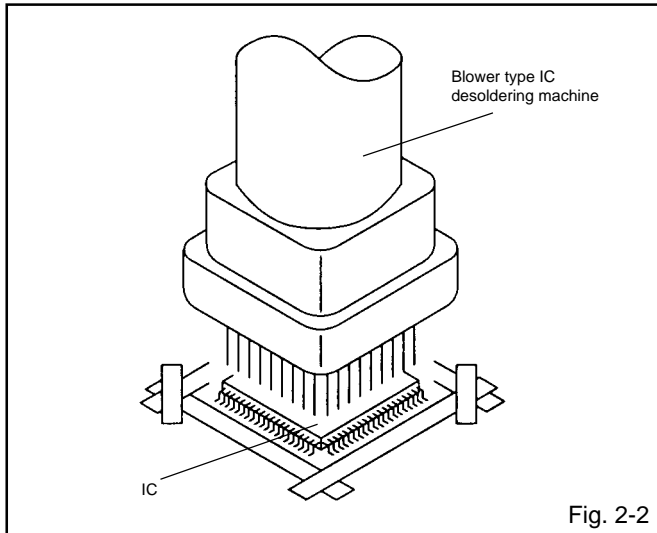

3. When IC starts moving back and forth easily after desoldering completely, pickup the corner of the IC using a tweezers and remove the IC by moving with the IC desoldering machine. (Refer to Fig. 2-3.)

NOTE

Some ICs on the PCB are affixed with glue, so be careful not to break or damage the foil of each IC leads or solder lands under the IC when removing it.

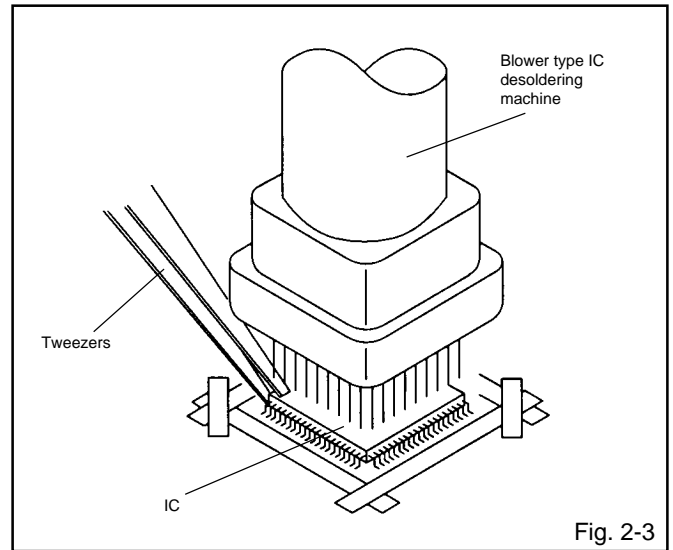

4. Peel off the Masking Tape.

5. Absorb the solder left on the pattern using the Braided Shield Wire. (Refer to Fig. 2-4.)

NOTE

Do not move the Braided Shield Wire in the vertical direction towards the IC pattern.

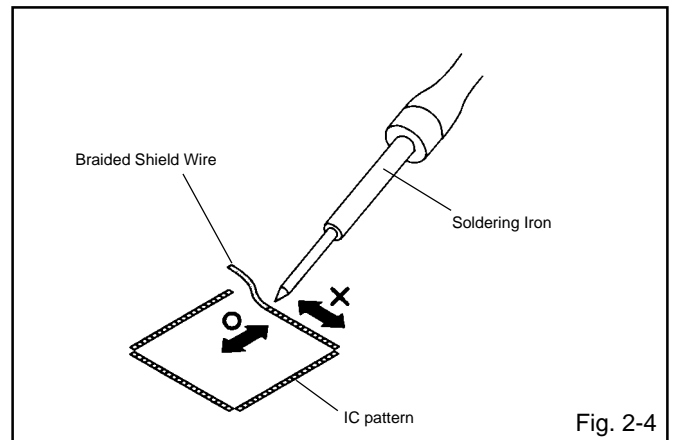

DISASSEMBLY INSTRUCTIONS

INSTALLATION

1. Take care of the polarity of new IC and then install the new IC fitting on the printed circuit pattern. Then solder each lead on the diagonal positions of IC temporarily. (Refer to Fig. 2-5.)

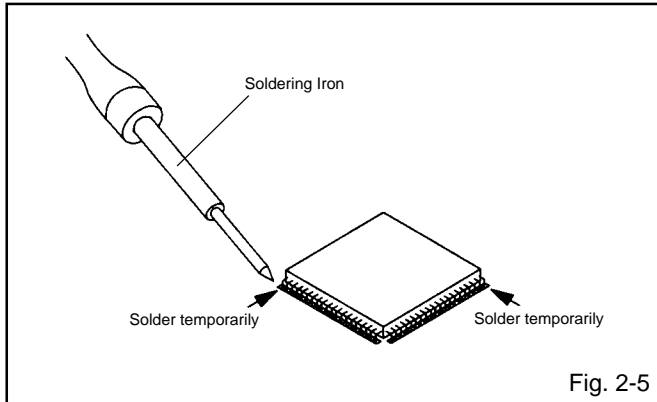

2. Supply the solder from the upper position of IC leads sliding to the lower position of the IC leads. (Refer to Fig. 2-6.)

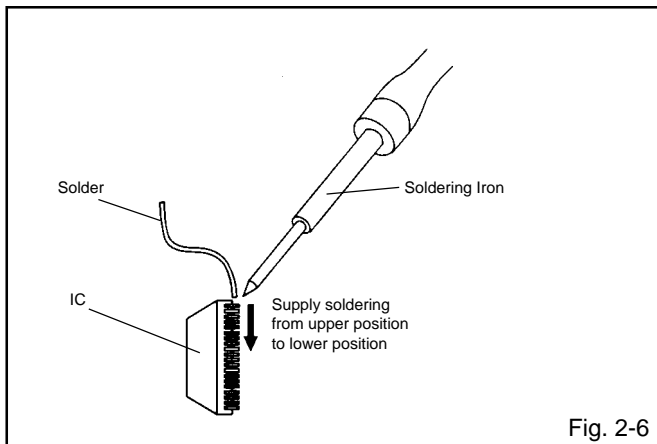

3. Absorb the solder left on the lead using the Braided Shield Wire. (Refer to Fig. 2-7.)

NOTE

Do not absorb the solder to excess.

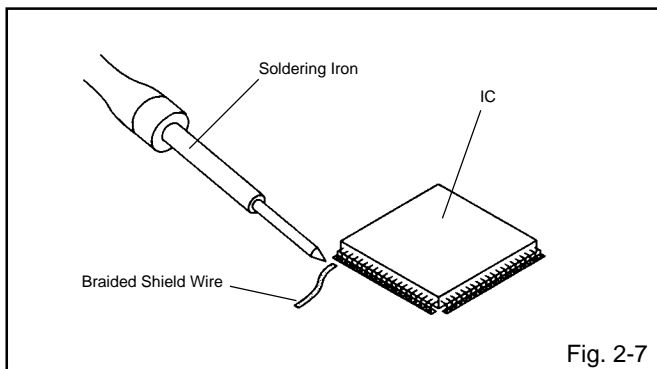

4. When bridge-soldering between terminals and/or the soldering amount are not enough, resolder using a Thin-tip Soldering Iron. (Refer to Fig. 2-8.)

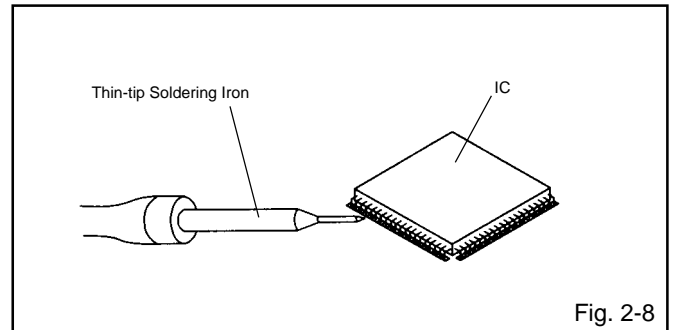

5. Finally, confirm the soldering status on four sides of the IC using a magnifying glass. Confirm that no abnormality is found on the soldering position and installation position of the parts around the IC. If some abnormality is found, correct by resoldering.

NOTE

When the IC leads are bent during soldering and/or repairing, do not repair the bending of leads. If the bending of leads are repaired, the pattern may be damaged. So, always be sure to replace the IC in this case.

SERVICE MODE LIST

This unit provided with the following SERVICE MODES so you can repair, examine and adjust easily. To enter the Service Mode, press both set key and remote control key for more than 1 second.

Set Key	Remocon Key	Operations
VOL. (-) MIN	0	Releasing of V-CHIP PASSWORD.
VOL. (-) MIN	1	Initialization of the factory. NOTE: Do not use this for the normal servicing. If you set a factory initialization, the memories are reset such as the channel setting, and the POWER ON total hours.
VOL. (-) MIN	6	POWER ON total hours is displayed on the screen. Refer to the "CONFIRMATION OF HOURS USED". Can be checked of the INITIAL DATA of MEMORY IC. Refer to the "WHEN REPLACING EEPROM (MEMORY) IC".
VOL. (-) MIN	8	Writing of EEPROM initial data. NOTE: Do not use this for the normal servicing.
VOL. (-) MIN	9	Display of the Adjustment MENU on the screen. Refer to the "ELECTRICAL ADJUSTMENT" (On-Screen Display Adjustment).

CONFIRMATION OF HOURS USED

POWER ON total hours can be checked on the screen. Total hours are displayed in 16 system of notation.

NOTE: If you set a factory initialization, the total hours is reset to "0".

1. Set the VOLUME to minimum.
2. Press both VOL. DOWN button on the set and Channel button (6) on the remote control for more than 1 second.
3. After the confirmation of using hours, turn off the power.

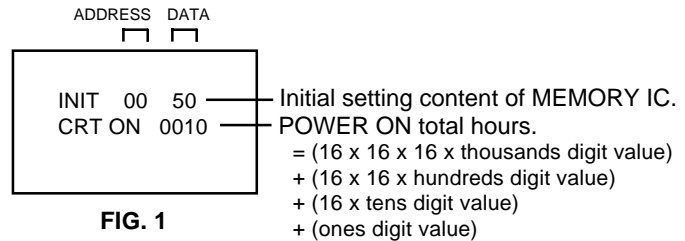

WHEN REPLACING EEPROM (MEMORY) IC

If a service repair is undertaken where it has been required to change the MEMORY IC, the following steps should be taken to ensure correct data settings while making reference to TABLE 1.

NOTE: No need setting for after INI 1F due to the adjustment value.

INI	+0	+1	+2	+3	+4	+5	+6	+7	+8	+9	+A	+B	+C	+D	+E	+F
00	50	E8	08	A5	5C	B3	34	77	3D	AC	AA	25	30	30	30	0A
10	0A	00	00	00	00	00	08	00	80	00	80	C0	A4	88	35	00

Table 1

1. Enter DATA SET mode by setting VOLUME to minimum.
 2. Press both VOL. DOWN button on the set and Channel button (6) on the remote control for more than 1 second. ADDRESS and DATA should appear as FIG 1.
 3. ADDRESS is now selected and should "blink". Using the VOL. UP/DOWN button on the remote, step through the ADDRESS until required ADDRESS to be changed is reached.
 4. Press ENTER to select DATA. When DATA is selected, it will "blink".
 5. Again, step through the DATA using VOL. UP/DOWN button until required DATA value has been selected.
 6. Pressing ENTER will take you back to ADDRESS for further selection if necessary.
 7. Repeat steps 3 to 6 until all data has been checked.
 8. When satisfied correct DATA has been entered, turn POWER off (return to STANDBY MODE) to finish DATA input.
After the data input, set to the initializing of shipping.
 9. Turn POWER on.
 10. Press both VOL. DOWN button on the set and Channel button (1) on the remote control for more than 1 second.
 11. After the finishing of the initializing of shipping, the unit will turn off automatically.
- The unit will now have the correct DATA for the new MEMORY IC.

ELECTRICAL ADJUSTMENTS

1. ADJUSTMENT PROCEDURE

Read and perform these adjustments when repairing the circuits or replacing electrical parts or PCB assemblies.

CAUTION

- Use an isolation transformer when performing any service on this chassis.
- Before removing the anode cap, discharge electricity because it contains high voltage.
- When removing a PCB or related component, after unfastening or changing a wire, be sure to put the wire back in its original position.
- When you exchange IC and Transistor for a heat sink, apply the silicon grease on the contact section of the heat sink. Before applying new silicon grease, remove all the old silicon grease. (Old grease may cause damages to the IC and Transistor.)

Prepare the following measurement tools for electrical adjustments.

1. Oscilloscope
2. Digital Voltmeter
3. Multi-sound Generator
4. Pattern Generator

On-Screen Display Adjustment

1. In the condition of NO indication on the screen. Press the VOL. DOWN button on the set and the Channel button (9) on the remote control for more than 1 second to appear the adjustment mode on the screen as shown in Fig. 1-1.

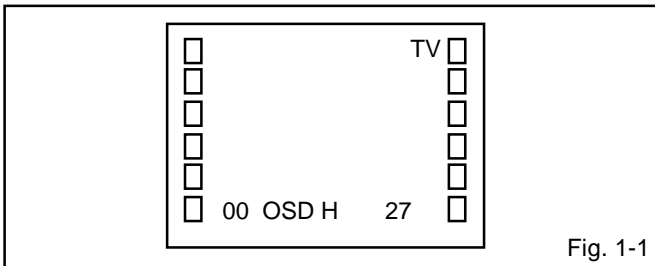

Fig. 1-1

3. Use the Channel UP/DOWN button or Channel button (0-9) on the remote control to select the options shown in Fig. 1-2.
4. Press the MENU button on the remote control to end the adjustments.

NO. FUNCTION	NO. FUNCTION	NO. FUNCTION
00 OSD H	16 BRIGHT CENT	31 E/W CORNER
01 CUT OFF	17 BRIGHT MIN	32 E/W TRAPEZIUM
02 H. VCO	18 CONTRAST MAX	33 LEVEL
03 H. PHASE	19 CONTRAST CENT	34 SEPARATION1
05 V. SHIFT	20 CONTRAST MIN	35 SEPARATION2
06 H. SIZE	21 COLOR MAX	51 DRIVE R COOL
07 V. SIZE	22 COLOR CENTER	52 DRIVE B COOL
08 V. LINEARITY	23 COLOR MIN	53 R BIAS COOL
09 VS CORRECTION	24 TINT	54 G BIAS COOL
10 DRIVE R MEDIUM	25 SHARPNESS	55 B BIAS COOL
11 DRIVE B MEDIUM	26 Cb DELAY FINE	56 DRIVE R WARM
12 R BIAS MEDIUM	27 Cr DELAY FINE	57 DRIVE B WARM
13 G BIAS MEDIUM	28 Cb PEDESTAL ADJ	58 R BIAS WARM
14 B BIAS MEDIUM	29 Cr PEDESTAL ADJ	59 G BIAS WARM
15 BRIGHT MAX	30 E/W PARABOLA	60 B BIAS WARM

Fig. 1-2

2. BASIC ADJUSTMENTS

2-1: CONSTANT VOLTAGE

1. Place the set with Aging Test for more than 5 minutes.
2. Set condition is AV MODE without signal.
3. Connect the digital voltmeter to the TP003.
4. Adjust the VR502 until the digital voltmeter is $135 \pm 1V$.

2-2: CUT OFF

1. Place the set with Aging Test for more than 15 minutes.
2. Activate the adjustment mode display of Fig. 1-1 and press the channel button (01) on the remote control to select "CUT OFF".
3. Adjust the Screen Volume until a dim raster is obtained.

2-3: WHITE BALANCE

NOTE: Adjust after performing CUT OFF adjustment.

1. Place the set with Aging Test for more than 10 minutes.
2. Receive the gray scale pattern from the Pattern Generator.
3. Using the remote control, set the brightness and contrast to normal position.
4. Activate the adjustment mode display of Fig. 1-1 and press the channel button (12) on the remote control to select "R. BIAS".
5. Press the CH. UP/DOWN button on the remote control to select the "R. BIAS", "G. BIAS", "B. BIAS", "B. DRIVE" or "G. DRIVE".
6. Adjust the VOL. UP/DOWN button on the remote control to whiten the R. BIAS, G. BIAS, B. BIAS, B. DRIVE, and G. DRIVE at each step tone sections equally.
7. Perform the above adjustments 5 and 6 until the white color is looked like a white.

2-4: FOCUS

1. Receive the monoscope pattern.
2. Turn the Focus Volume fully counterclockwise once.
3. Adjust the Focus Volume until picture is distinct.

2-5: HORIZONTAL PHASE

1. Receive the monoscope pattern.
2. Using the remote control, set the brightness and contrast to normal position.
3. Activate the adjustment mode display of Fig. 1-1 and press the channel button (03) on the remote control to select "H. PHAS".
4. Press the VOL. UP/DOWN button on the remote control until the SHIFT quantity of the OVER SCAN on right and left becomes minimum.

ELECTRICAL ADJUSTMENTS

2-6: HORIZONTAL SIZE

1. Receive the monoscope pattern.
2. Using the remote control, set the brightness and contrast to normal position.
3. Activate the adjustment mode display of **Fig. 1-1** and press the channel button **(06)** on the remote control to select "H. SIZE".
4. Press the VOL. UP/DOWN button on the remote control until the SHIFT quantity of the OVER SCAN on right and left becomes $11 \pm 1\%$.

2-7: VERTICAL POSITION

1. Receive the monoscope pattern.
2. Using the remote control, set the brightness and contrast to normal position.
3. Adjust the **VR401** until the horizontal line becomes fit to the notch of the shadow mask.

2-8: VERTICAL SIZE

1. Receive the monoscope pattern.
2. Using the remote control, set the brightness and contrast to normal position.
3. Activate the adjustment mode display of **Fig. 1-1** and press the channel button **(07)** on the remote control to select "V. SIZE".
4. Press the VOL. UP/DOWN button on the remote control until the SHIFT quantity of the OVER SCAN on upside and downside becomes $9 \pm 2\%$.

2-9: VERTICAL LINEARITY

NOTE: Adjust after performing adjustments in section 2-8. After the adjustment of Vertical Linearity, reconfirm the Vertical Position and Vertical Size adjustments.

1. Receive the monoscope pattern.
2. Using the remote control, set the brightness and contrast to normal position.
3. Activate the adjustment mode display of **Fig. 1-1** and press the channel button **(08)** on the remote control to select "V. LIN".
4. Press the VOL. UP/DOWN button on the remote control until the SHIFT quantity of the OVER SCAN on upside and downside becomes minimum.

2-10: LEVEL

1. Receive the VHF HIGH (70dB).
2. Connect the AC voltmeter to **pin 6 of CP101**.
3. Activate the adjustment mode display of **Fig. 1-1** and press the channel button **(33)** on the remote control to select "LEVEL".
4. Press the VOL. UP/DOWN button on the remote control until the AC voltmeter is $85 \pm 2\text{mV}$.

2-11: E/W CORNER

1. Receive the crosshatch signal from the Pattern Generator.
2. Set the screen mode to 4:3.
3. Using the remote control, set the brightness and contrast to normal position.
4. Activate the adjustment mode display of **Fig. 1-1** and press the channel button **(31)** on the remote control to select "COR TOP".
5. Press the VOL. UP/DOWN button on the remote control until the right and left vertical lines are straight.
6. Set the screen mode to 16:9. Then perform the above adjustments 4~5.

2-12: E/W PARABOLA

1. Receive the crosshatch signal from the Pattern Generator.
2. Set the screen mode to 4:3.
3. Using the remote control, set the brightness and contrast to normal position.
4. Activate the adjustment mode display of **Fig. 1-1** and press the channel button **(30)** on the remote control to select "PARABOLA".
5. Press the VOL. UP/DOWN button on the remote control until the right and left vertical lines are straight.
6. Set the screen mode to 16:9. Then perform the above adjustments 4~5.

2-13: TRAPEZIUM

1. Receive the crosshatch signal from the Pattern Generator.
2. Using the remote control, set the brightness and contrast to normal position.
3. Activate the adjustment mode display of **Fig. 1-1** and press the channel button **(32)** on the remote control to select "TRAPEZIUM".
4. Press the VOL. UP/DOWN button on the remote control until the both vertical lines of the screen become parallel.

2-14: SEPARATION 1, 2

Please do the method (1) or method (2) adjustment.

Method (1)

1. Set the multi-sound signal generator for each different L-ch and R-ch frequency (Ex. L-ch=2KHz, R-ch=400Hz) and receive the RF.
2. Connect the oscilloscope to the **Audio Out Jack**.
3. Activate the adjustment mode display of **Fig. 1-1** and press the channel button **(34)** on the remote control to select "SEP 1".
4. Press the VOL. UP/DOWN button on the remote control to adjust it until the audio output wave becomes a fine sine wave.
5. Press the CH UP button once the set to "SEP 2" mode. Then perform the above adjustment 4.

ELECTRICAL ADJUSTMENTS

Method (2)

1. Set the multi-sound signal generator L-ch=1KHz, R-ch =Non input and receive the RF.
2. Connect the oscilloscope to the **Audio Out Jack (R-ch)**.
3. Press the AUDIO SELECT button on the remote control to set to the stereo mode.
4. Activate the adjustment mode display of **Fig. 1-1** and press the channel button **(34)** on the remote control to select "SEP 1".
5. Press the VOL. UP/DOWN button on the remote control to adjust it until the R-ch output becomes minimum.
6. Set the multi-sound signal generator L-ch=Non input, R-ch=1KHz and receive the RF.
7. Connect the oscilloscope to the **Audio Out Jack (L-ch)**.
8. Activate the adjustment mode display of **Fig. 1-1** and press the channel button **(35)** on the remote control to select "SEP 2".
9. Press the VOL. UP/DOWN button on the remote control to adjust it until the L-ch output becomes minimum.

2-15: BRIGHT CENT

1. Receive the monoscope pattern. (RF Input)
2. Using the remote control, set the brightness and contrast to normal position.
3. Activate the adjustment mode display of **Fig. 1-1** and press the channel button **(16)** on the remote control to select "BRI CENT".
4. Press the VOL. UP/DOWN button on the remote control until the white 0% is starting to be visible
5. Receive the monoscope pattern. (Audio Video Input)
6. Press the TV/VIDEO button on the remote control to set to the AV mode. Then perform the above adjustments 2~4.
7. Press the TV/VIDEO button on the remote control to set to the CS mode.
8. Activate the adjustment mode display of **Fig. 1-1** and press the channel button **(16)** on the remote control to select "BRI CENT".
9. Press the VOL. UP/DOWN button on the remote control until the brightness step No. becomes "60".
10. Receive a broadcast and check if the picture is normal.

2-16: TINT/COLOR CENT

1. Receive the color bar pattern.
2. Connect the oscilloscope to **TP806**.
3. Activate the adjustment mode display of **Fig. 1-1** and press the channel button **(24)** on the remote control to select "TINT".
4. Press the VOL. UP/DOWN button on the remote control until the section "A" becomes as straight line **(Refer to Fig. 2-1)**
5. Press the VOL. UP/DOWN button on the remote control until the 7 step up becomes as straight line
6. Connect the oscilloscope to **TP804**.
7. Activate the adjustment mode display of **Fig. 1-1** and press the channel button **(22)** on the remote control to select "COL.CENT".
8. Press the VOL. UP/DOWN button on the remote control until the red color level is adjusted to $120 \pm 10\%$ of the white level. **(Refer to Fig. 2-2)**
9. Receive the color bar pattern. (Audio Video Input)
10. Press the TV/VIDEO button on the remote control to set to the AV mode. Then perform the above adjustments 2~8.
11. Press the TV/VIDEO button on the remote control to set to the CS mode.
12. Activate the adjustment mode display of **Fig. 1-1** and press the channel button **(24)** on the remote control to select "TINT".
13. Press the VOL. UP/DOWN button on the remote control until the tint step No. becomes "50".
14. Activate the adjustment mode display of **Fig. 1-1** and press the channel button **(22)** on the remote control to select "COL.CENT".
15. Press the VOL. UP/DOWN button on the remote control until the color step No. becomes "65".
16. Receive a broadcast and check if the picture is normal.

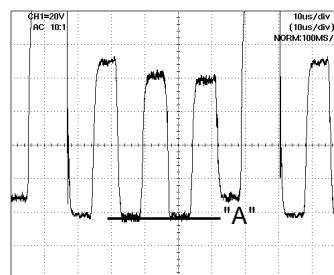

Fig. 2-1

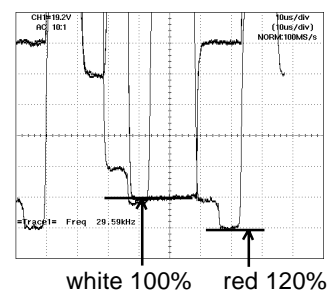

Fig. 2-2

ELECTRICAL ADJUSTMENTS

2-17: CONTRAST MAX MANUAL

1. Activate the adjustment mode display of **Fig. 1-1** and press the channel button **(18)** on the remote control to select "CONT. MAX".
2. Press the VOL. UP/DOWN button on the remote control until the contrast step No. becomes "64".
3. Receive a broadcast and check if the picture is normal.
4. Press the TV/VIDEO button on the remote control to set to the AV mode. Then perform the above adjustments 1~3.
5. Press the TV/VIDEO button on the remote control to set to the CS mode. Then perform the above adjustments 1~3.

2-18: Confirmation of Fixed Value (Step No.)

Please check if the fixed values of the each adjustment items are set correctly referring below. (RF/AV/CS)

NO.	FUNCTION	STEP NO.	NO.	FUNCTION	STEP NO.
00	OSD H	27	21	COL.MAX	80
02	H.VCO	03	23	COL.MIN	00
05	V.SHIFT	02	25	SHARPNESS	40
09	VS.CORRECTION	25	26	CB DL	00
15	BRI.MAX	105	27	CR DL	00
17	BRI.MIN	55	28	CB PED	08
19	CONT.CENT	60	29	CR PED	08
20	CONT.MIN	10			

ELECTRICAL ADJUSTMENTS

3. PURITY AND CONVERGENCE ADJUSTMENTS

NOTE

1. Turn the unit on and let it warm up for at least 30 minutes before performing the following adjustments.
2. Place the CRT surface facing east or west to reduce the terrestrial magnetism.
3. Turn ON the unit and demagnetize with a Degauss Coil.

3-1: STATIC CONVERGENCE (ROUGH ADJUSTMENT)

1. Tighten the screw for the magnet. Refer to the adjusted CRT for the position. **(Refer to Fig. 3-1)**
If the deflection yoke and magnet are in one body, untighten the screw for the body.
2. Receive the green raster pattern from the color bar generator.
3. Slide the deflection yoke until it touches the funnel side of the CRT.
4. Adjust center of screen to green, with red and blue on the sides, using the pair of purity magnets.
5. Switch the color bar generator from the green raster pattern to the crosshatch pattern.
6. Combine red and blue of the 3 color crosshatch pattern on the center of the screen by adjusting the pair of 4 pole magnets.
7. Combine red/blue (magenta) and green by adjusting the pair of 6 pole magnets.
8. Adjust the crosshatch pattern to change to white by repeating steps 6 and 7.

3-2: PURITY

NOTE

Adjust after performing adjustments in section 3-1.

1. Receive the green raster pattern from color bar generator.
2. Adjust the pair of purity magnets to center the color on the screen.
Adjust the pair of purity magnets so the color at the ends are equally wide.
3. Move the deflection yoke backward (to neck side) slowly, and stop it at the position when the whole screen is green.
4. Confirm red and blue color.
5. Adjust the slant of the deflection yoke while watching the screen, then tighten the fixing screw.

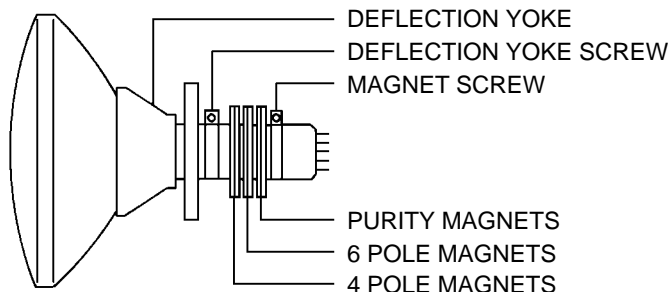

Fig. 3-1

3-3: STATIC CONVERGENCE

NOTE

Adjust after performing adjustments in section 3-2.

1. Receive the crosshatch pattern from the color bar generator.
2. Combine red and blue of the 3 color crosshatch pattern on the center of the screen by adjusting the pair of 4 pole magnets.
3. Combine red/blue (magenta) and green by adjusting the pair of 6 pole magnets.

3-4: DYNAMIC CONVERGENCE

NOTE

Adjust after performing adjustments in section 3-3.

1. Adjust the differences around the screen by moving the deflection yoke upward/downward and right/left. **(Refer to Fig. 3-2-a)**
2. Insert three wedges between the deflection yoke and CRT funnel to fix the deflection yoke. **(Refer to Fig. 3-2-b)**

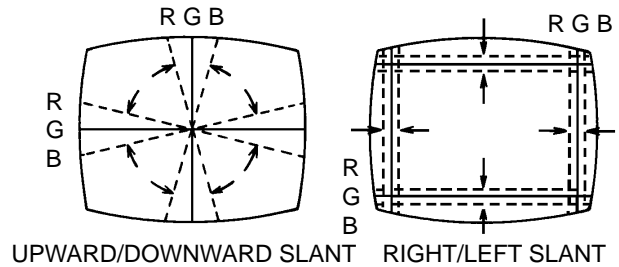
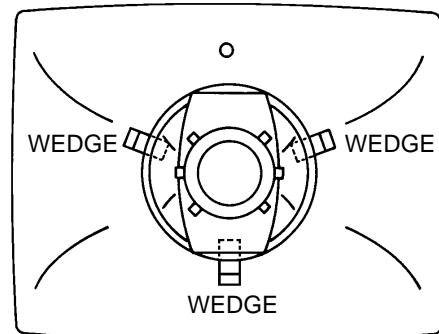

Fig. 3-2-a



WEDGE POSITION

Fig. 3-2-b

ELECTRICAL ADJUSTMENTS

4. ELECTRICAL ADJUSTMENT PARTS LOCATION GUIDE (WIRING CONNECTION)

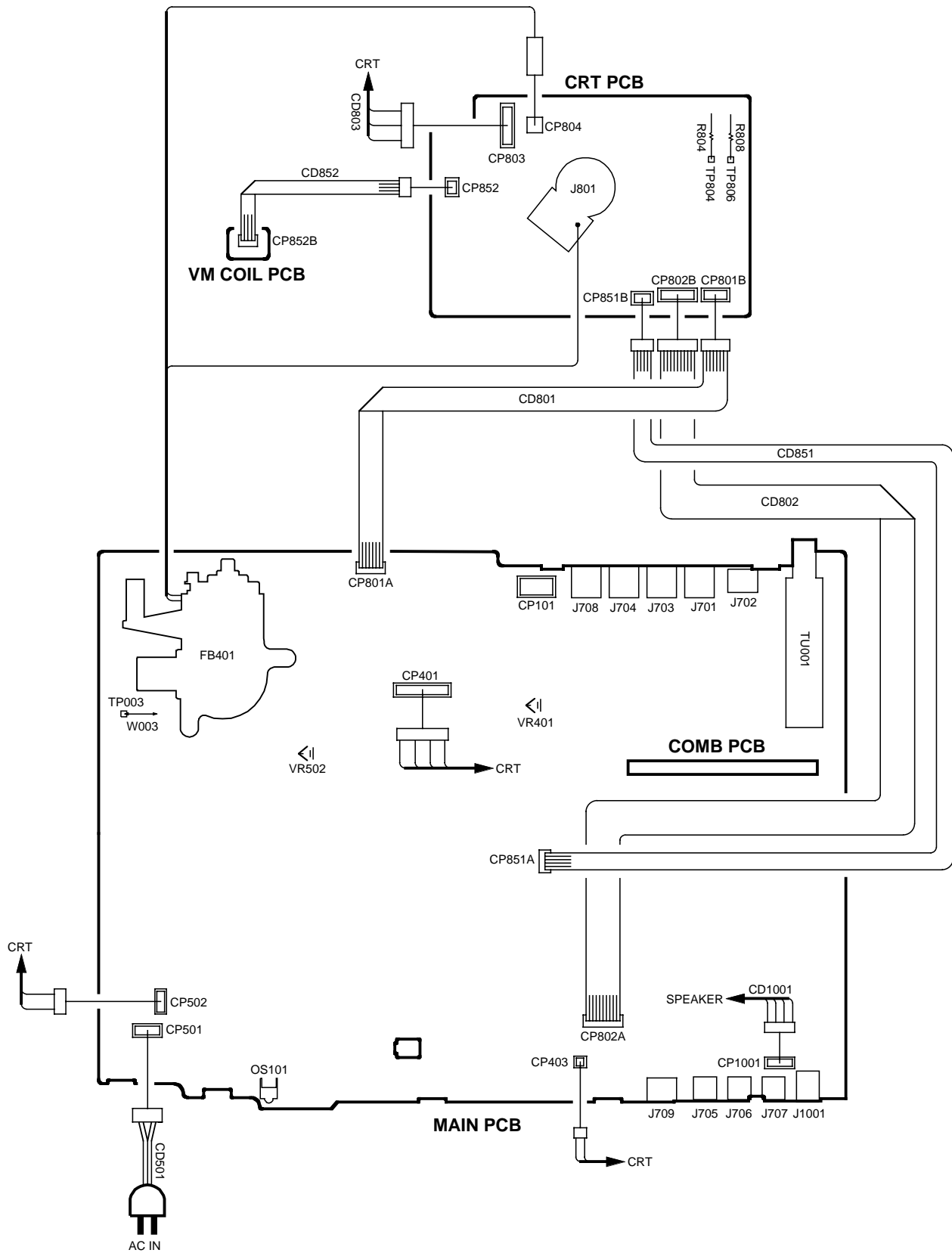

BLOCK DIAGRAM

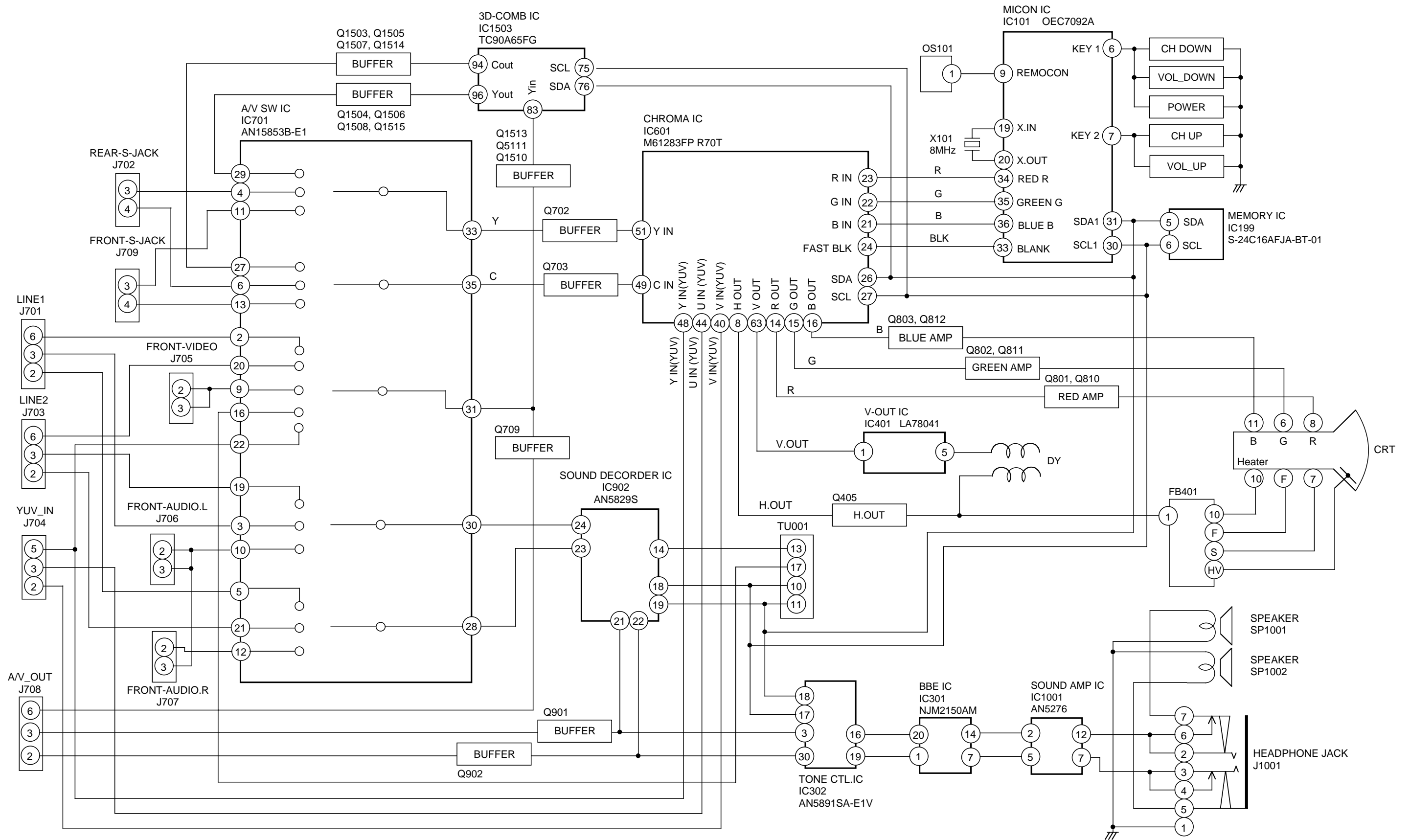

PRINTED CIRCUIT BOARDS

CRT/VM COIL SOLDER SIDE

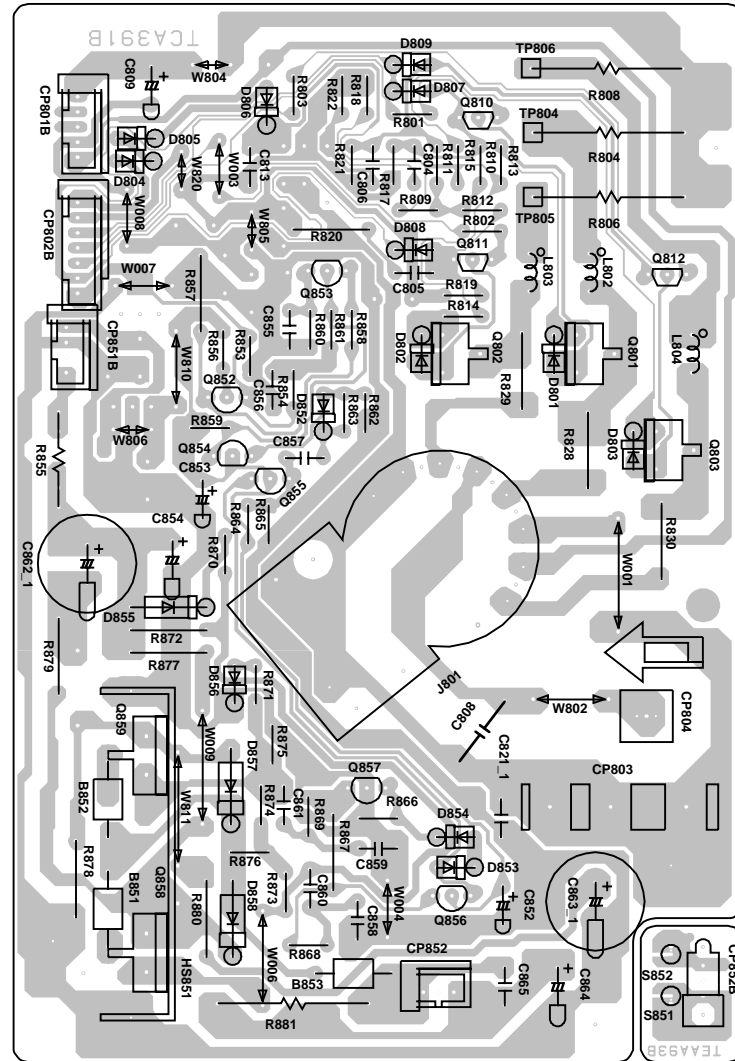

COMB (TOP SIDE) SOLDER SIDE

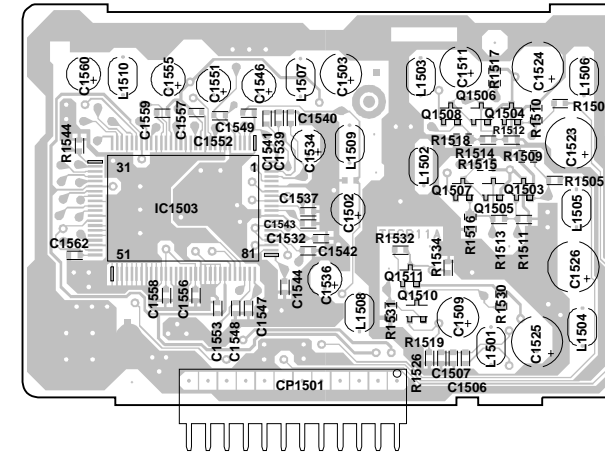

COMB (BOTTOM SIDE) SOLDER SIDE

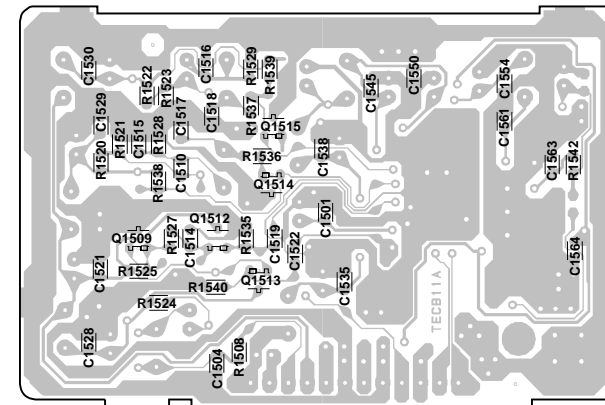

MICON SCHEMATIC DIAGRAM (MAIN PCB)

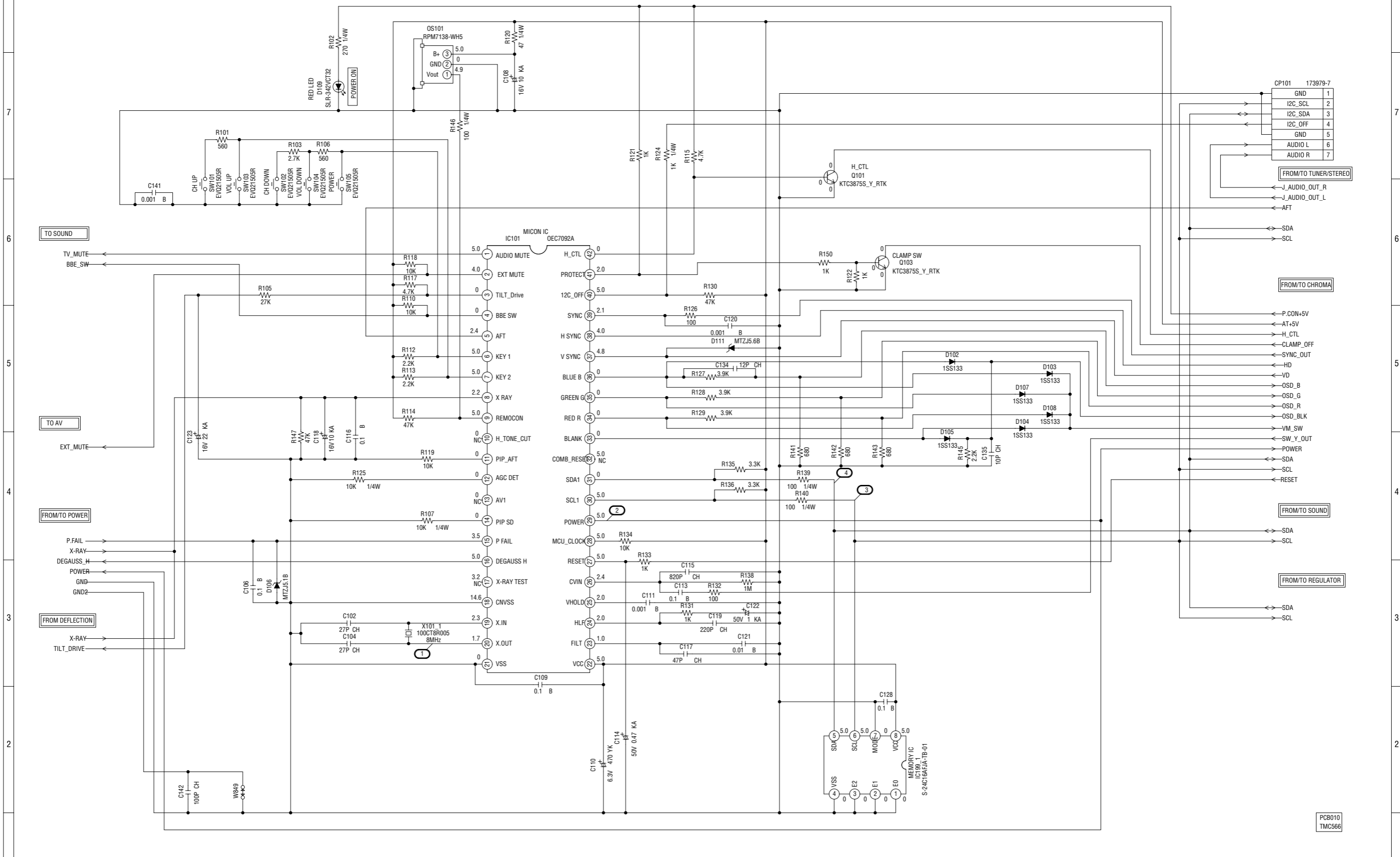

NOTE: THIS SCHEMATIC DIAGRAM IS THE LATEST AT THE TIME OF PRINTING AND SUBJECT TO CHANGE WITHOUT NOTICE.

NOTE: THE DC VOLTAGE AT EACH PART WAS MEASURED WITH THE DIGITAL TESTER WHEN THE COLOR BROADCAST WAS RECEIVED IN GOOD CONDITION AND PICTURE IS NORMAL.

PCB010
TMC566

CHROMA SCHEMATIC DIAGRAM (MAIN PCB)

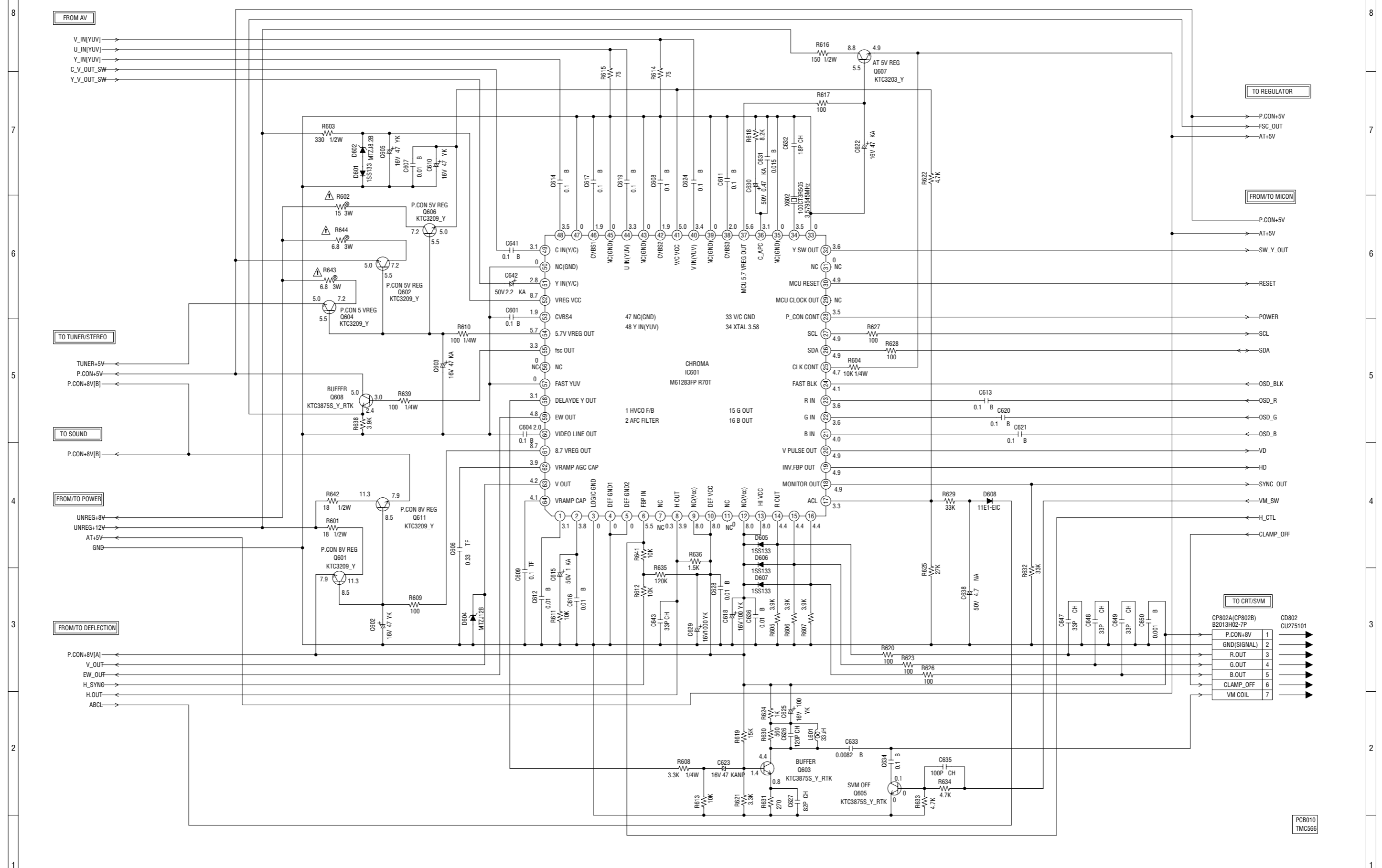

NOTE: THIS SCHEMATIC DIAGRAM IS THE LATEST AT THE TIME OF PRINTING AND SUBJECT TO CHANGE WITHOUT NOTICE.

NOTE: THE DC VOLTAGE AT EACH PART WAS MEASURED WITH THE DIGITAL TESTER WHEN THE COLOR BROADCAST WAS RECEIVED IN GOOD CONDITION AND PICTURE IS NORMAL.

TO CRT/SVM	
P.CON+8V	1
GND(SIGNAL)	2
R.OUT	3
G.OUT	4
B.OUT	5
CLAMP_OFF	6
VM COIL	7

PCB010
TMC566

DEFLECTION SCHEMATIC DIAGRAM (MAIN PCB)

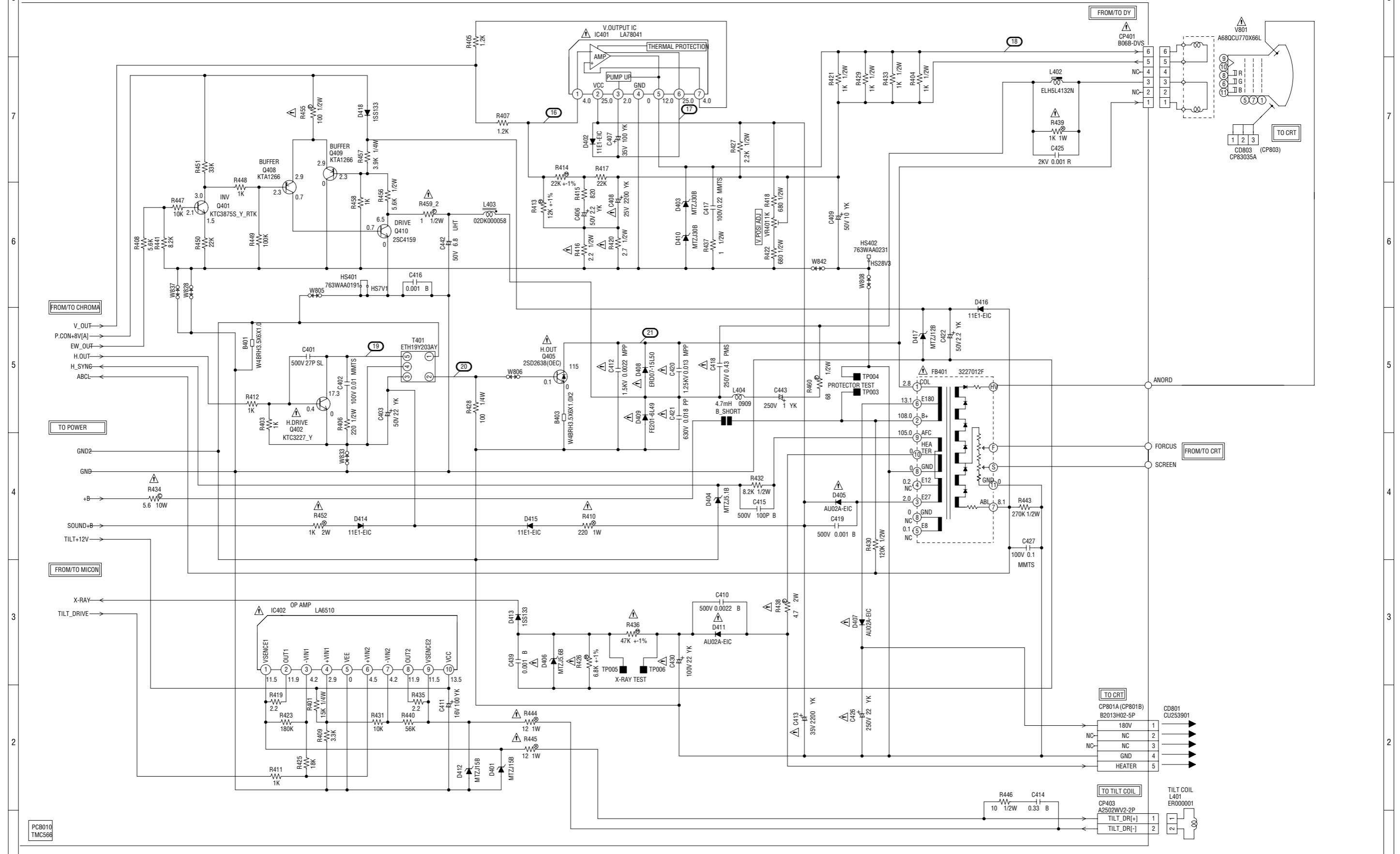

NOTE: THIS SCHEMATIC DIAGRAM IS THE LATEST AT THE TIME OF PRINTING AND SUBJECT TO CHANGE WITHOUT NOTICE.

NOTE: THE RESISTOR MARKED F IS FUSE RESISTOR. THE ALUMI ELECTROLYTIC CAPACITOR MARKED NP IS NON POLAR ONE.

NOTE: THE DC VOLTAGE AT EACH PART WAS MEASURED WITH THE DIGITAL TESTER WHEN THE COLOR BROADCAST WAS RECEIVED IN GOOD CONDITION AND PICTURE IS NORMAL.

ATTENTION - LES PIECES REPARÉES PAR UN ETANT DANGEREUSES AN POINT DE VUE SECURITE N'UTILISER QUE CELLS DECRITES DANS LA NOMENCLATURE DES PIECES.

CAUTION - SINCE THESE PARTS MARKED BY ARE CRITICAL FOR SAFETY, USE ONES DESCRIBED IN PARTS LIST ONLY.

POWER SCHEMATIC DIAGRAM (MAIN PCB)

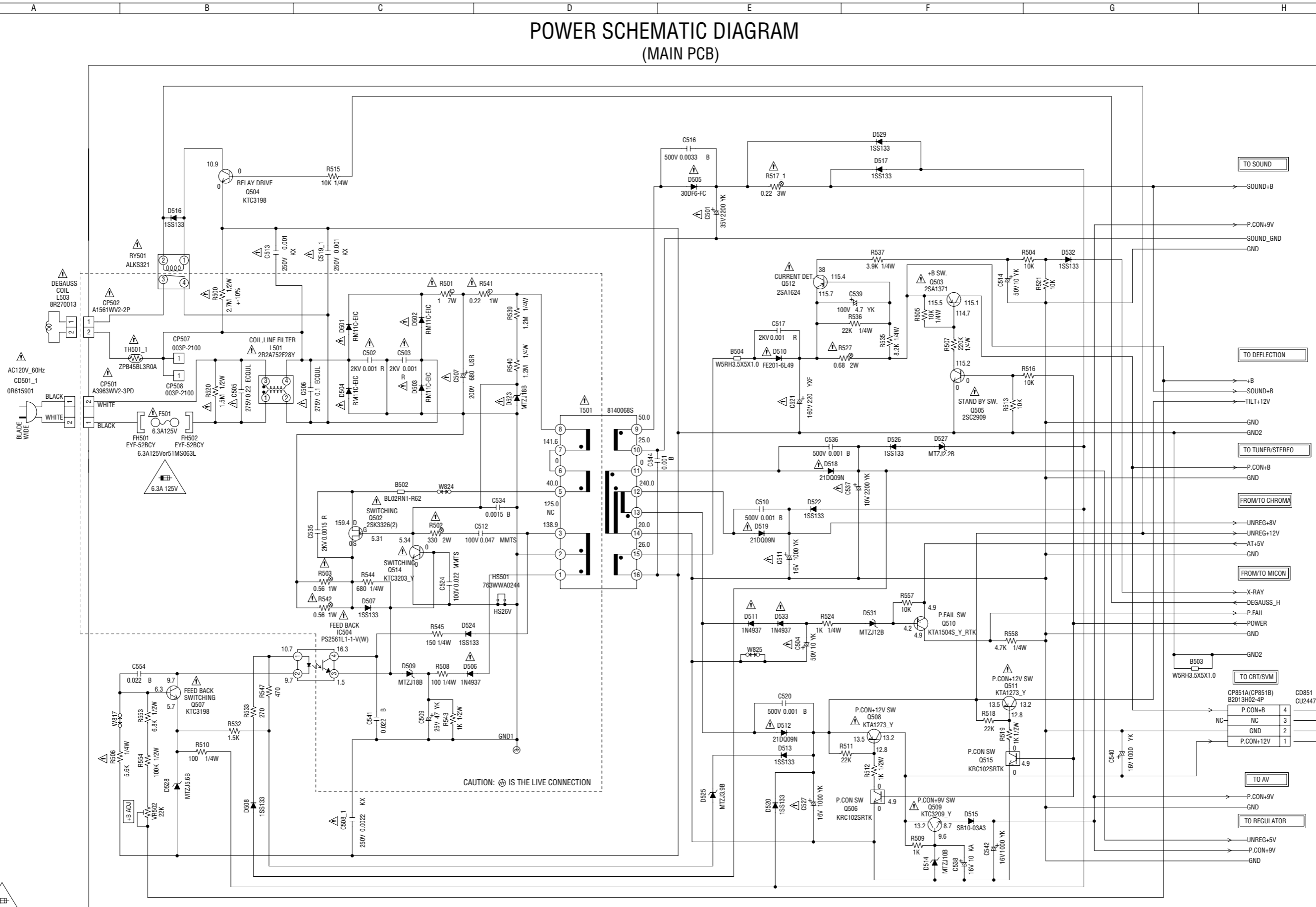

CAUTION FOR CONTINUED PROTECTION AGAINST FIRE HAZARD, REPLACE ONLY WITH THE SAME TYPE FUSE 6.3V 125V(F501).

ATTENTION POUR UNE PROTECTION CONTINUE LES RISQUES D'INCEIE N'UTILISER QUE DES FUSIBLE DE MEME TYPE 6.3V 125V(F501).

NOTE: THIS SCHEMATIC DIAGRAM IS THE LATEST AT THE TIME OF PRINTING AND SUBJECT TO CHANGE WITHOUT NOTICE.

NOTE: THE DC VOLTAGE AT EACH PART WAS MEASURED WITH THE DIGITAL TESTER WHEN THE COLOR BROADCAST WAS RECEIVED IN GOOD CONDITION AND PICTURE IS NORMAL.

NOTE: THE RESISTOR MARKED F IS FUSE RESISTOR. THE ALUMI ELECTROLYTIC CAPACITOR MARKED NP IS NON POLAR ONE.

ATTENTION LES PIECES REPARÉES PAR UN ETANT DANGEREUSES AN POINT DE VUE SECURITE N'UTILISER QUE CELLS DECRITES DANS LA NOMENCLATURE DES PIECES.

CAUTION SINCE THESE PARTS MARKED ARE CRITICAL FOR SAFETY, USE ONES DESCRIBED IN PARTS LIST ONLY.

CAUTION: DIGITAL TRANSISTOR

SOUND SCHEMATIC DIAGRAM (MAIN PCB)

FROM TUNER/STEREO

AUDIO_OUT_L
AUDIO_OUT_R

FROM CHROMA

P.CON+8V[B]

FROM/TO MICON

SDA
SCL
BBE_SW
TV_MUTE

FROM POWER

SOUND+B
P.CON+9V
GND
SOUND_GND

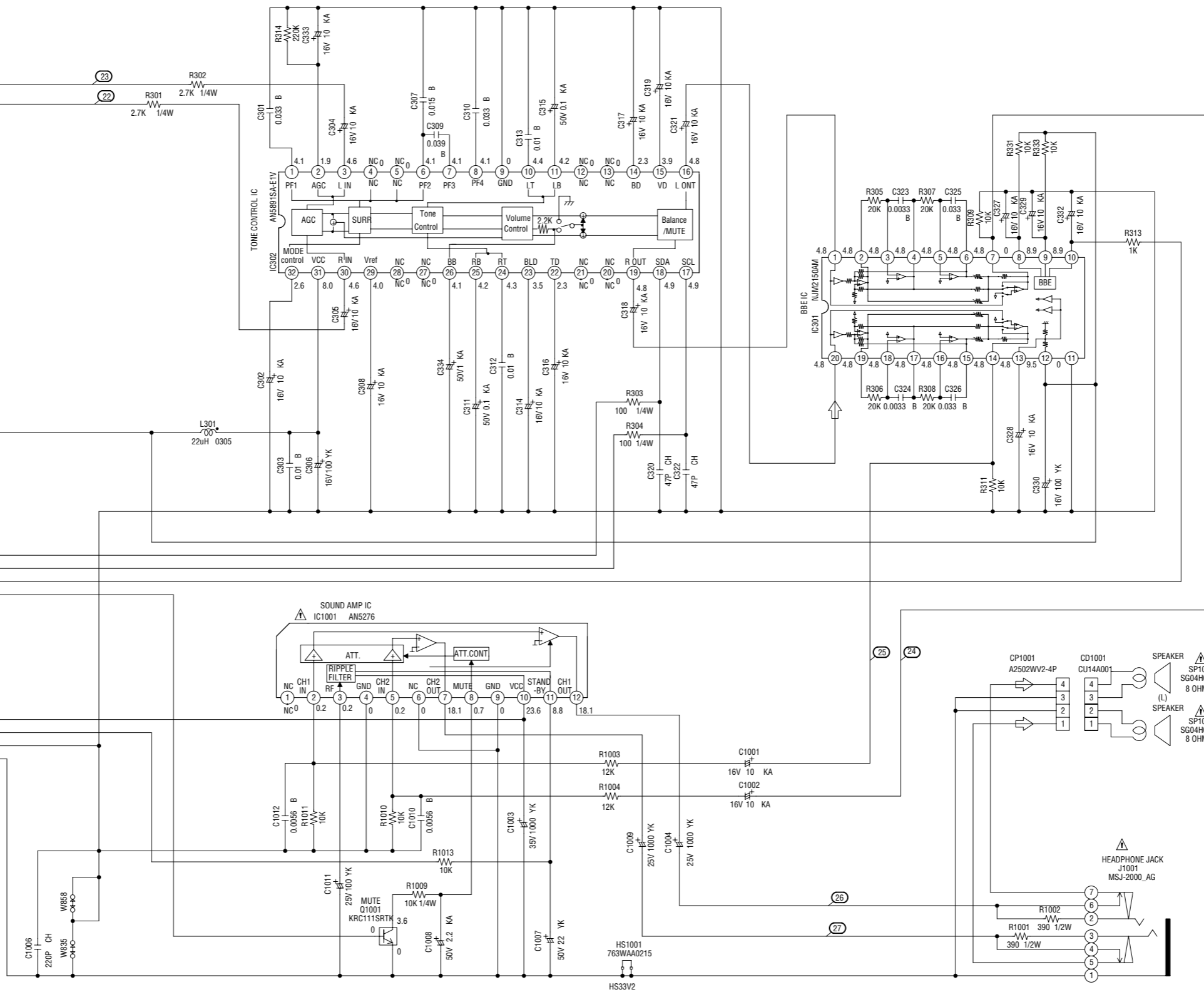

PCB010
TMC566

NOTE: THIS SCHEMATIC DIAGRAM IS THE LATEST AT THE TIME OF PRINTING AND SUBJECT TO CHANGE WITHOUT NOTICE.

NOTE: THE DC VOLTAGE AT EACH PART WAS MEASURED WITH THE DIGITAL TESTER WHEN THE COLOR BROADCAST WAS RECEIVED IN GOOD CONDITION AND PICTURE IS NORMAL.

ATTENTION: LES PIÈCES RÉPARÉES PAR UN ÉTANT DANGEREUSES AN POINT DE VUE SECURITE N'UTILISER QUE CELLES DÉCRITES DANS LA NOMENCLATURE DES PIÈCES.

CAUTION: SINCE THESE PARTS MARKED BY ARE CRITICAL FOR SAFETY, USE ONES DESCRIBED IN PARTS LIST ONLY.

CAUTION: DIGITAL TRANSISTOR

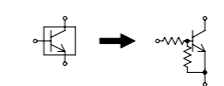

AUDIO SIGNAL (REC)

TUNER/STEREO SCHEMATIC DIAGRAM (MAIN PCB)

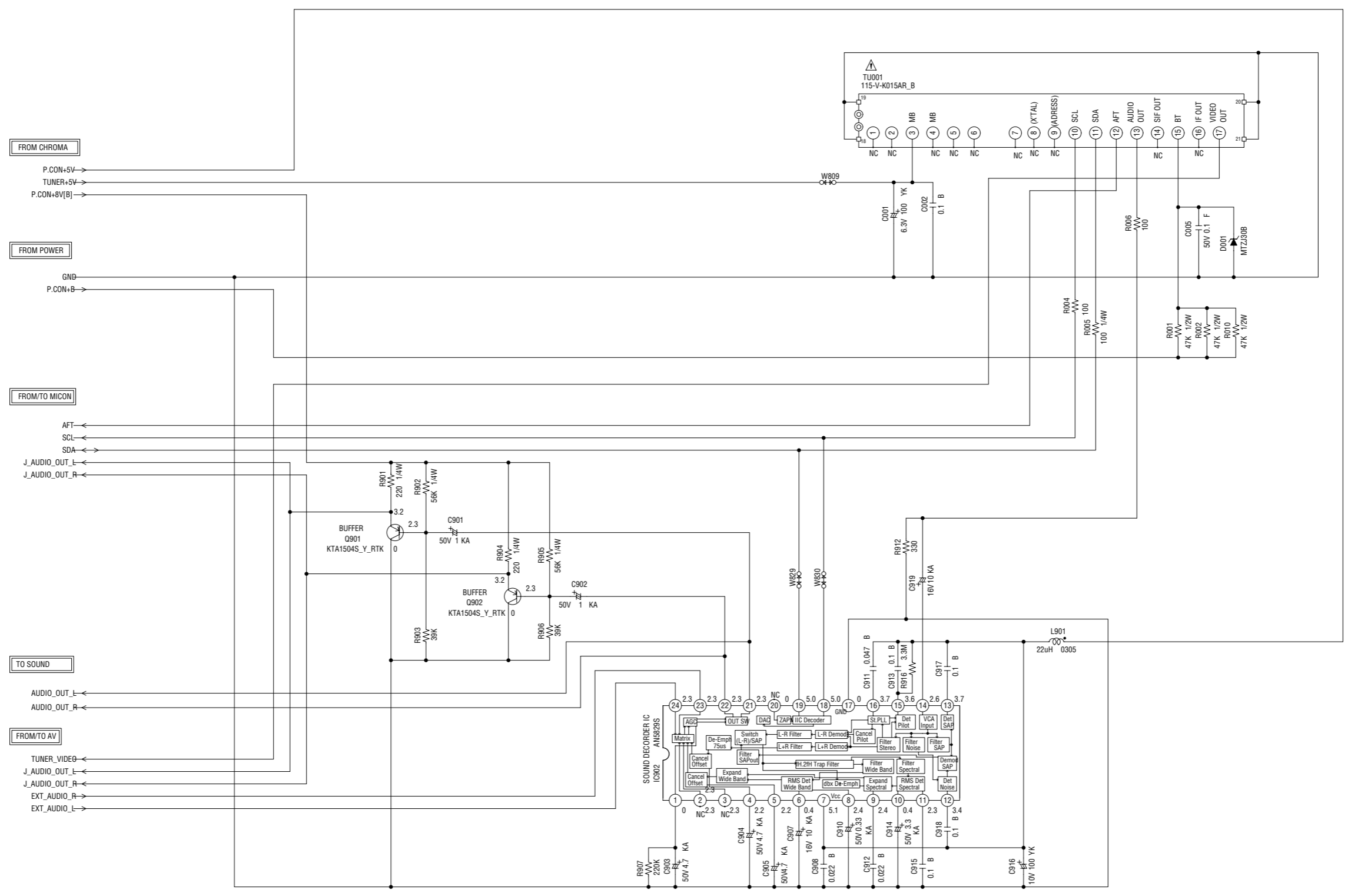

PCB010
TMC566

NOTE: THIS SCHEMATIC DIAGRAM IS THE LATEST AT THE TIME OF PRINTING AND SUBJECT TO CHANGE WITHOUT NOTICE.

NOTE: THE DC VOLTAGE AT EACH PART WAS MEASURED WITH THE DIGITAL TESTER WHEN THE COLOR BROADCAST WAS RECEIVED IN GOOD CONDITION AND PICTURE IS NORMAL.

ATTENTION: LES PIÈCES RÉPARÉES PAR UN ÉTANT DANGEREUSES AN POINT DE VUE SECURITE N'UTILISER QUE CELLS DÉCRITES DANS LA NOMENCLATURE DES PIÈCES.

CAUTION: SINCE THESE PARTS MARKED BY ARE CRITICAL FOR SAFETY, USE ONES DESCRIBED IN PARTS LIST ONLY.

AV SCHEMATIC DIAGRAM (MAIN PCB)

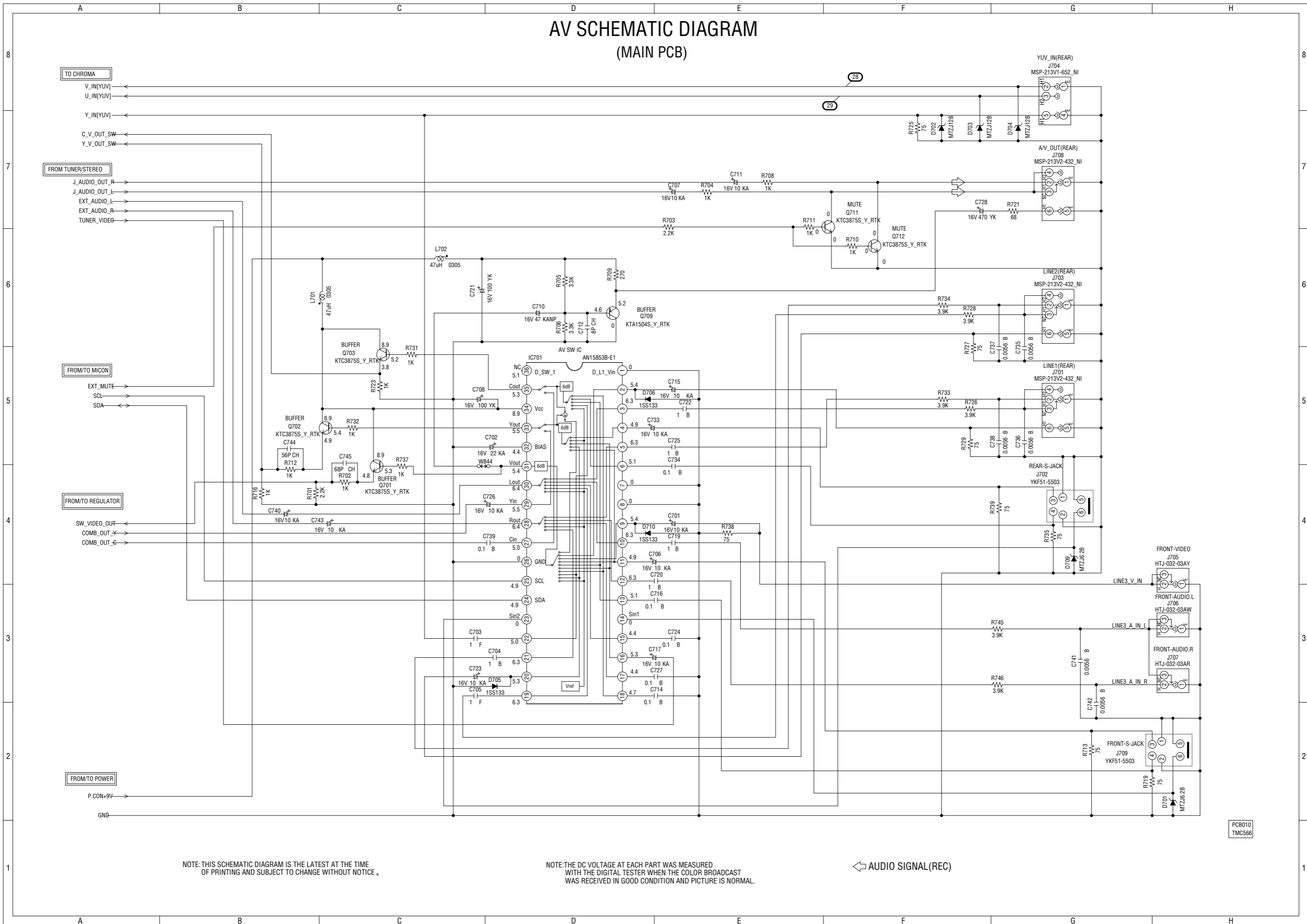

NOTE: THIS SCHEMATIC DIAGRAM IS THE LATEST AT THE TIME OF PRINTING AND SUBJECT TO CHANGE WITHOUT NOTICE.

NOTE: THE DC VOLTAGE AT EACH PART WAS MEASURED WITH THE DIGITAL TESTER WHEN THE COLOR BROADCAST WAS RECEIVED IN GOOD CONDITION AND PICTURE IS NORMAL.

← AUDIO SIGNAL (REC)

PCB010
TMC566

REGULATOR SCHEMATIC DIAGRAM

(MAIN PCB)

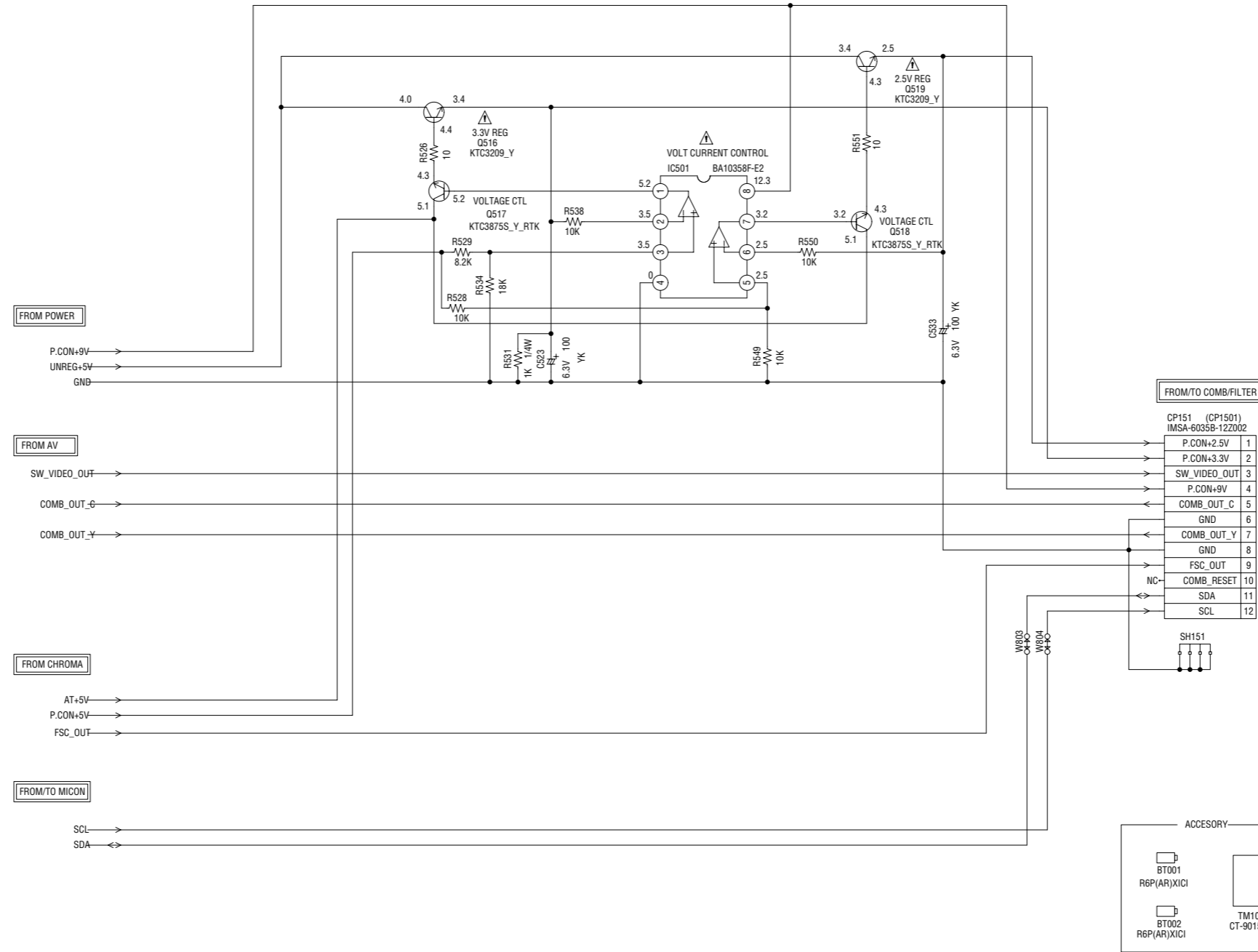

NOTE: THIS SCHEMATIC DIAGRAM IS THE LATEST AT THE TIME OF PRINTING AND SUBJECT TO CHANGE WITHOUT NOTICE.

NOTE: THE DC VOLTAGE EACH PART WAS MEASURED WITH THE DIGITAL TESTER DURING PLAYBACK.

ATTENTION : LES PIÈCES RÉPARÉES PAR UN ÉTANT DANGEREUSES AU POINT DE VUE SÉCURITÉ N'UTILISER QUE CELLES DÉCRITES DANS LA NOMENCLATURE DES PIÈCES.

CAUTION SINCE THESE PARTS MARKED BY ARE CRITICAL FOR SAFETY, USE ONES DESCRIBED IN PARTS LIST ONLY.

PCB010
TMC564

CRT/SVM SCHEMATIC DIAGRAM (CRT PCB)

CRT BLOCK

SVM BLOCK

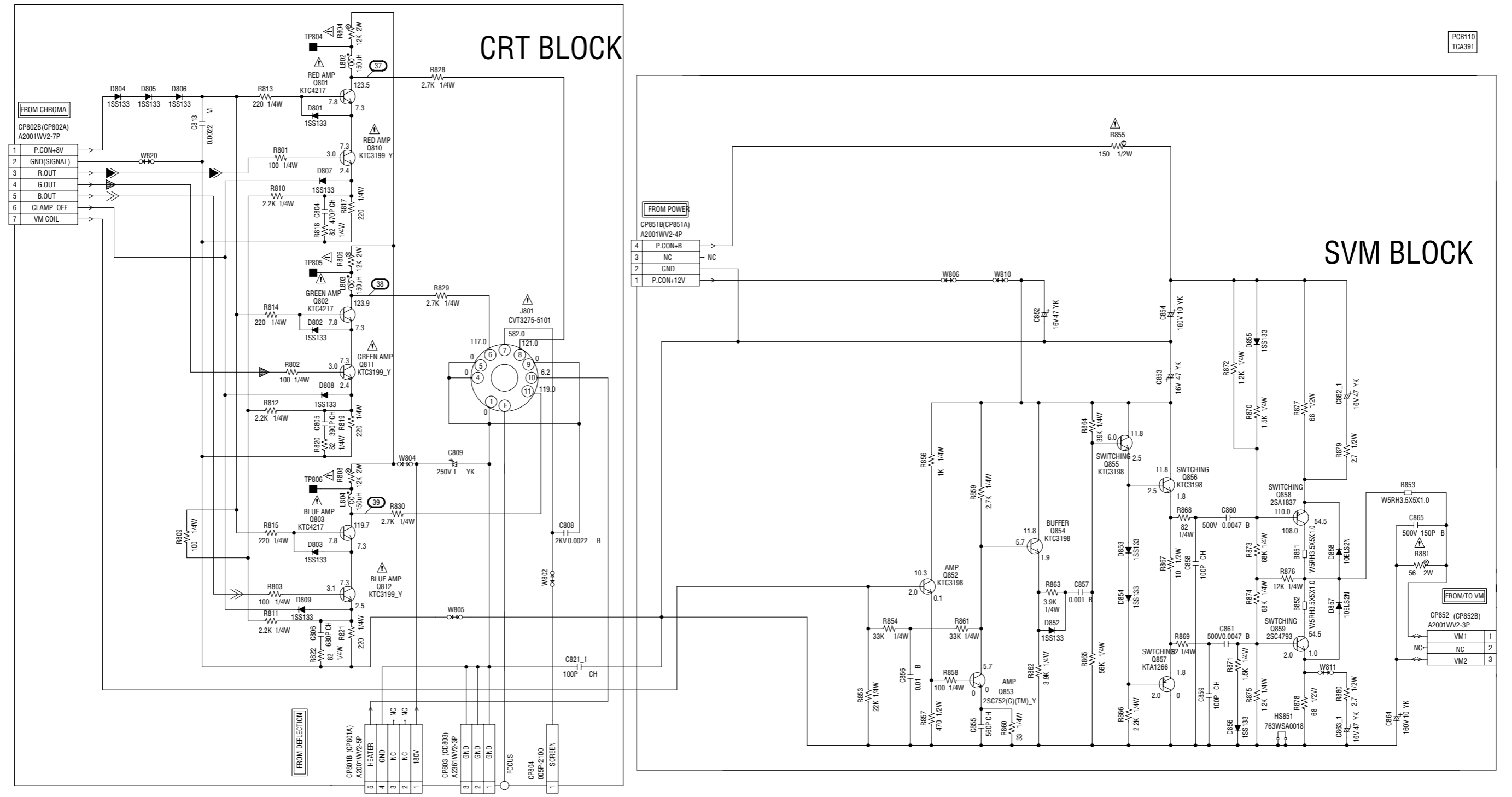

(VM COIL PCB)

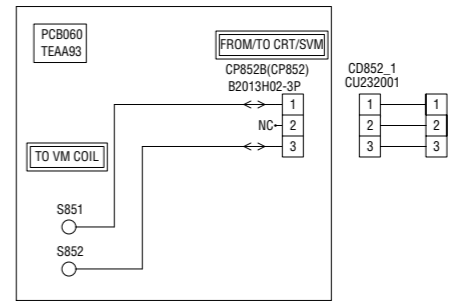

NOTE: THIS SCHEMATIC DIAGRAM IS THE LATEST AT THE TIME OF PRINTING AND SUBJECT TO CHANGE WITHOUT NOTICE.

NOTE: THE DC VOLTAGE AT EACH PART WAS MEASURED WITH THE DIGITAL TESTER WHEN THE COLOR BROADCAST WAS RECEIVED IN GOOD CONDITION AND PICTURE IS NORMAL.

ATTENTION: LES PIÈCES RÉPARÉES PAR UN ÉTANT DANGEREUSES AU POINT DE VUE SÉCURITÉ N'UTILISER QUE CELLES DÉCRITES DANS LA NOMENCLATURE DES PIÈCES.

CAUTION: SINCE THESE PARTS MARKED BY ARE CRITICAL FOR SAFETY, USE ONES DESCRIBED IN PARTS LIST ONLY.

R.SIGNAL
 G.SIGNAL
 B.SIGNAL

COMB/FILTER SCHEMATIC DIAGRAM

(COMB PCB)

FROM/TO REGULATOR

1	P.CON+2.5V	P.CON+2.5V
2	P.CON+3.3V	P.CON+3.3V
3	SW_VIDEO_OUT	SW_VIDEO_OUT
4	P.CON+9V	P.CON+9V
5	COMB_OUT_C	COMB_OUT_C
6	GND	GND
7	COMB_OUT_Y	COMB_OUT_Y
8	GND	GND
9	FSC_OUT	FSC_OUT
10	NC	NC
11	SDA	SDA
12	SCL	SCL

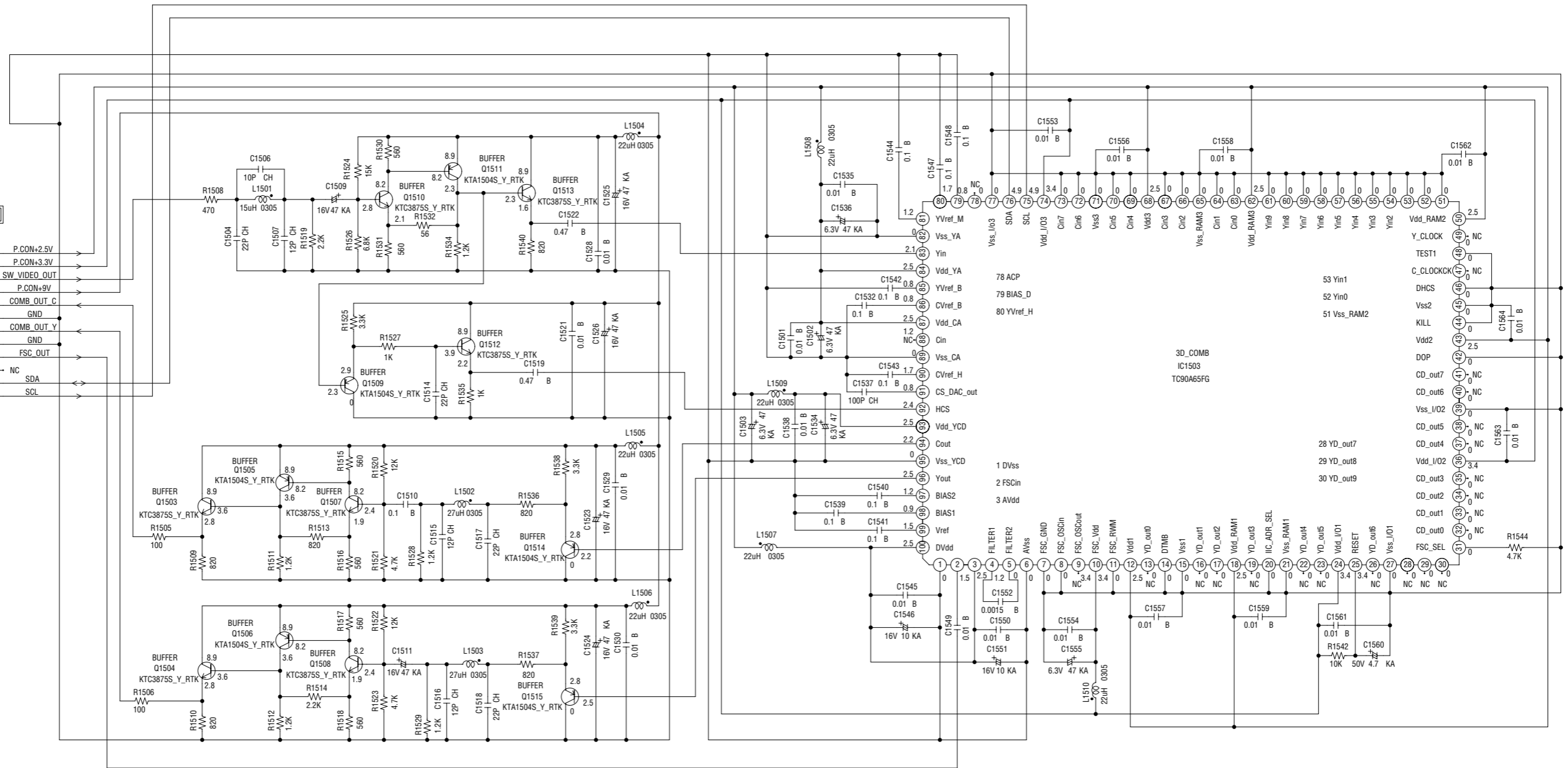

NOTE: THIS SCHEMATIC DIAGRAM IS THE LATEST AT THE TIME OF PRINTING AND SUBJECT TO CHANGE WITHOUT NOTICE.

NOTE: THE DC VOLTAGE AT EACH PART WAS MEASURED WITH THE DIGITAL TESTER WHEN THE COLOR BROADCAST WAS RECEIVED IN GOOD CONDITION AND PICTURE IS NORMAL.

PCB330
TECB11

WAVEFORMS

MICON

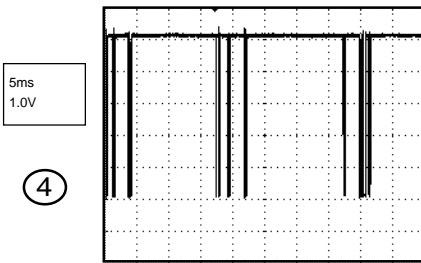
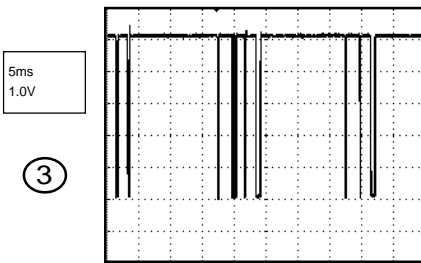
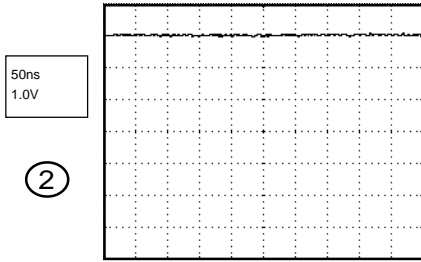
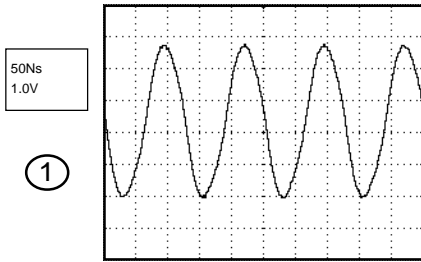

DEFLECTION

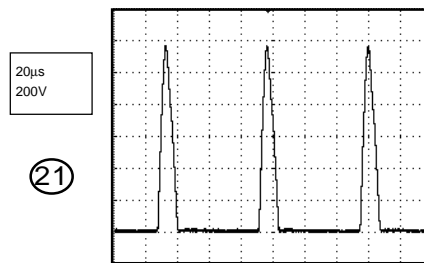
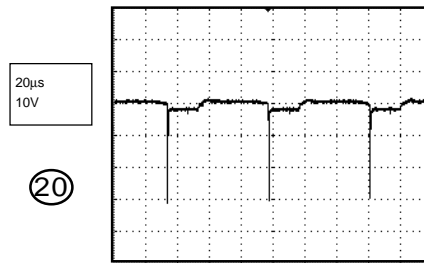
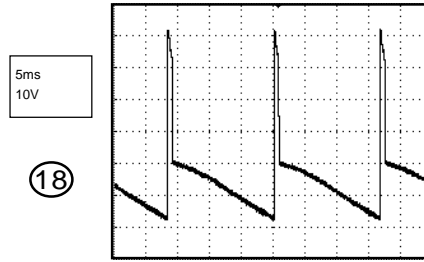
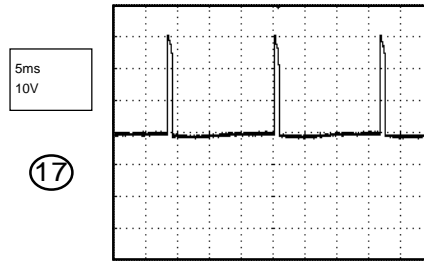
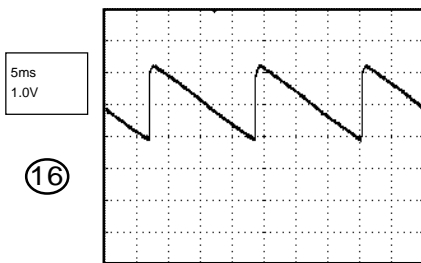

SOUND

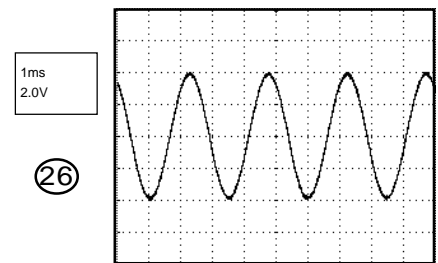
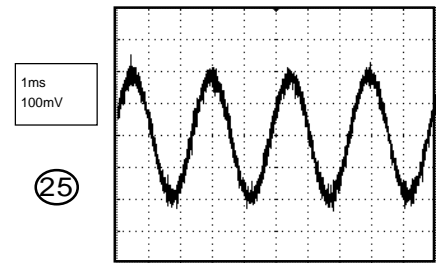
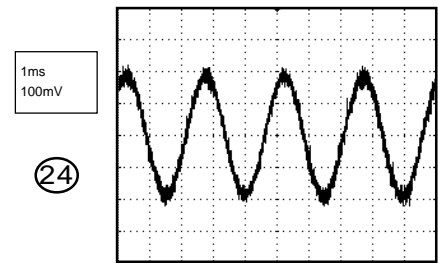
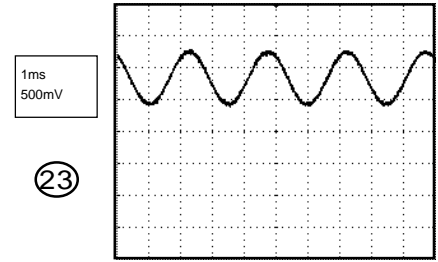
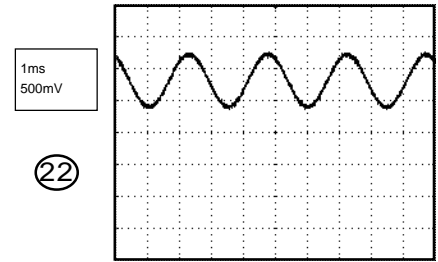

NOTE: The following waveforms were measured at the point of the corresponding balloon number in the schematic diagram.

WAVEFORMS

1ms
2.0V

27

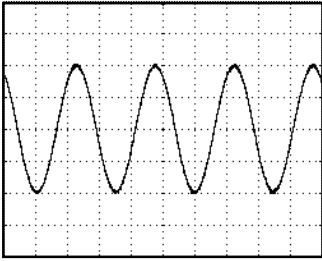

10μs
20V

39

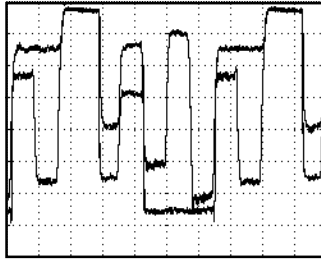

AV

20μs
200mV

28

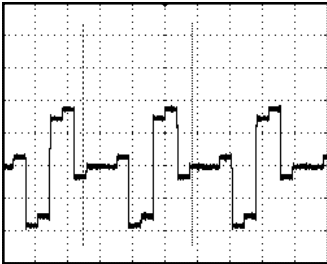

20μs
200mV

29

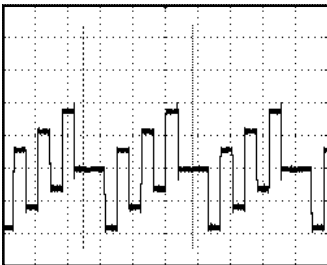

CRT/SVM

10μs
20V

37

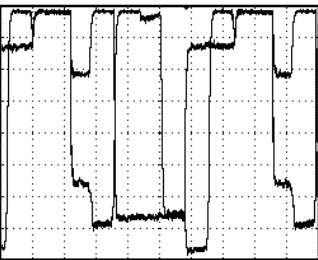

10μs
20V

38

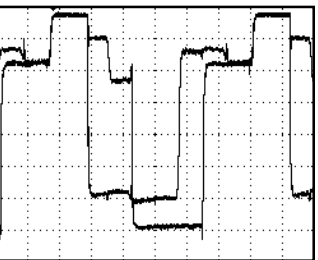

NOTE: The following waveforms were measured at the point of the corresponding balloon number in the schematic diagram.

MECHANICAL EXPLODED VIEW

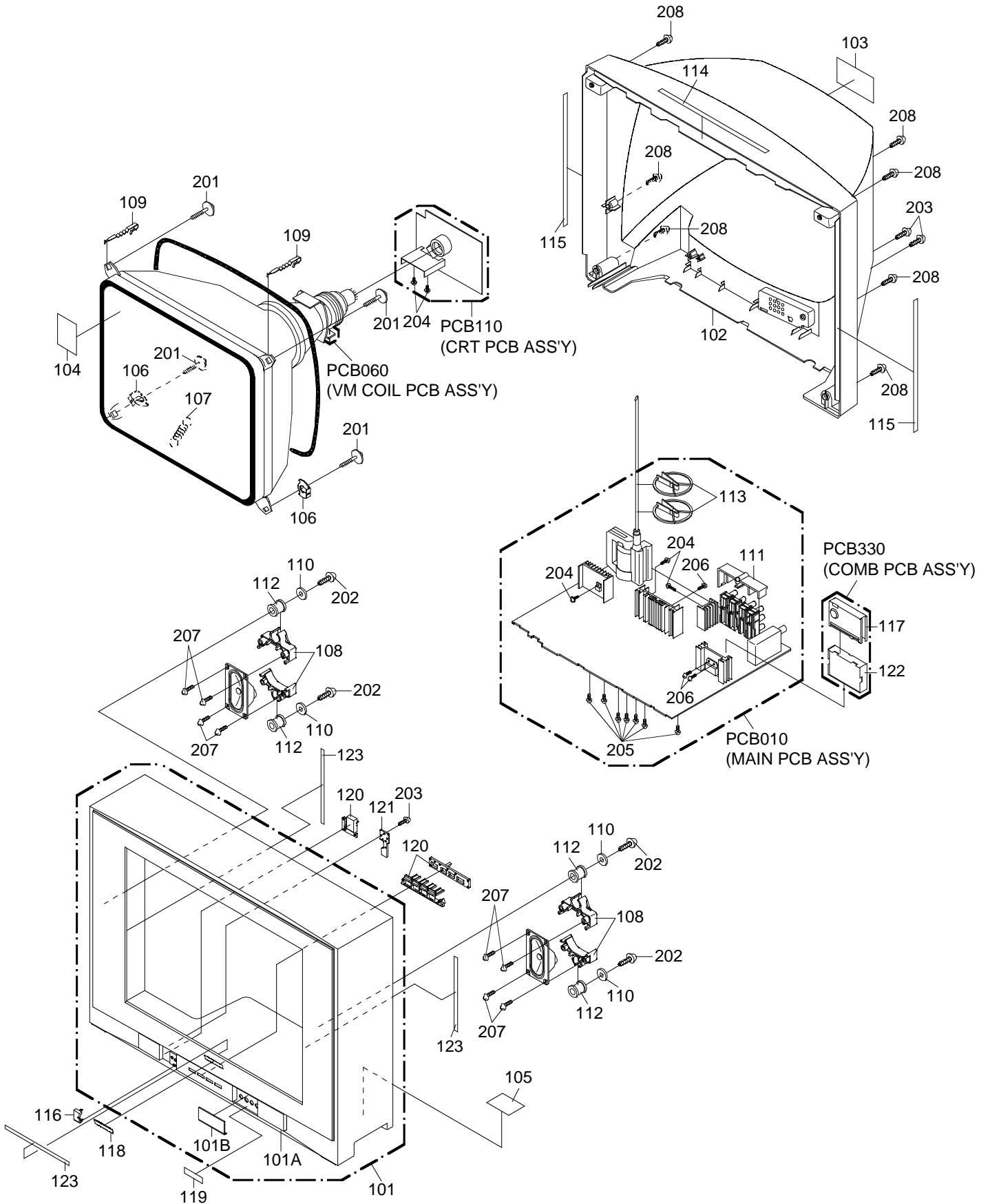

MECHANICAL EXPLODED VIEW (PACKING DIAGRAM)

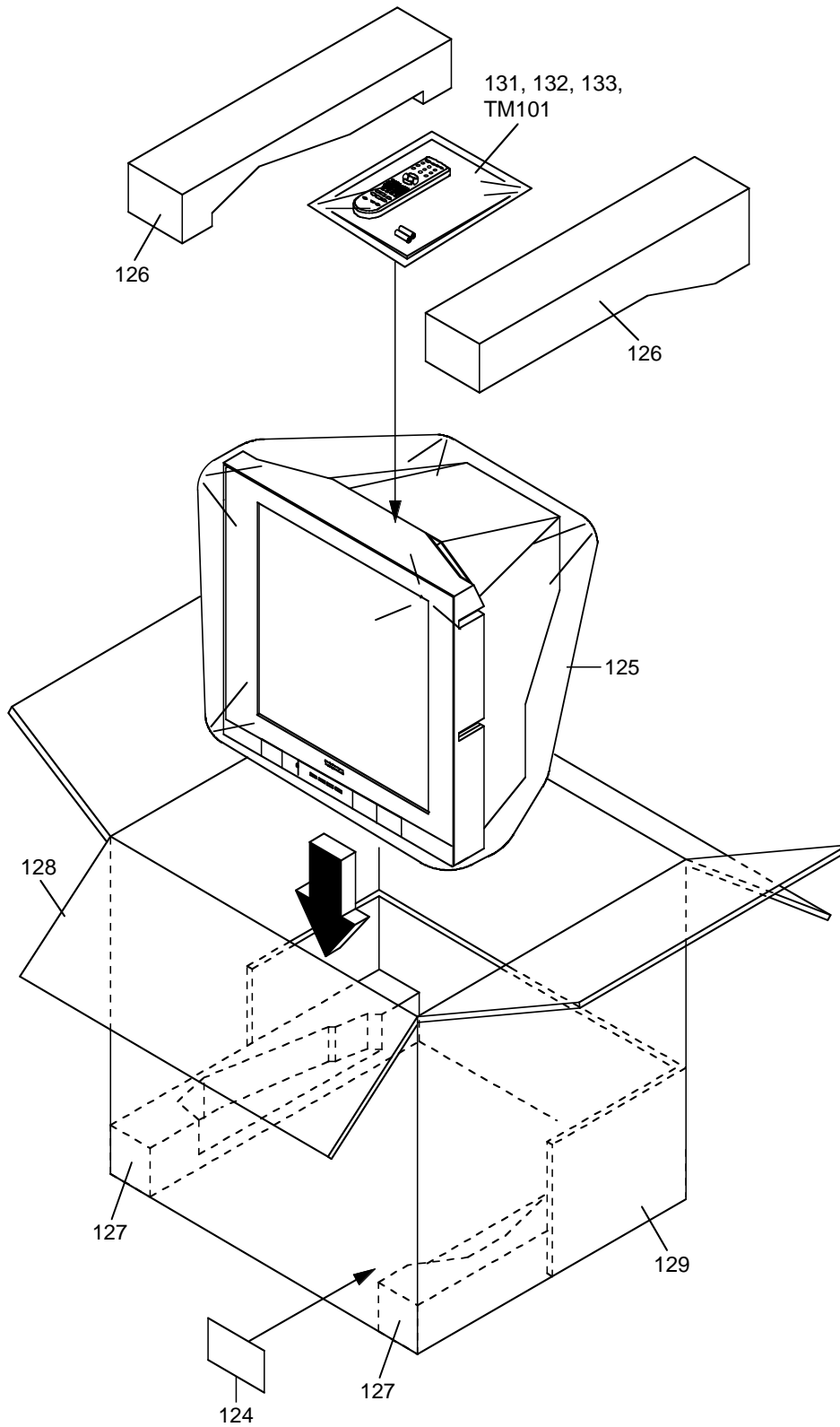

MECHANICAL REPLACEMENT PARTS LIST

Location No.	TSB P/N	Reference No.	Description	
101	AE003298	A3N116F720K	CABINET,FRONT ASSY	
101A	AE003299	701APJA134	CABINET,FRONT	
101B	AE003015	712APBA005	DOOR	
102	AE003300	A3N116F740K	CABINET,BACK ASSY	
103	AE003301	722549A323	SHEET,RATING	
104	AE001146	7235490040	FILM,DECORATION	
105	AD301425	7240001120	SHEET,CSA	
106	AE003019	769WSA0017	WASHER CRT T=1	
107	AD300759	741WUA0021	SPRING,EARTH	
108	AE003226	761WPAA090	HOLDER,SPEAKER	
109	BZ710259	762WPA0011	HOLDER,CRT WIRE	
110	AD300519	82A40B0104	FLAT WASHER	
111	AD301616	761WPA0263	HOLDER,JACK	
112	AD300518	801WR00001	DAMPER,SPEAKER	
113	BZ710260	899HV3T000	HOLDER,ANODE WIRE	
114	AE003020	800WQ0A050	FELT SHEET	
115	AE003021	800WQ0A072	FELT SHEET	
116	AE003302	711WPAA100	PLATE,FRONT ASS'Y	
117	BZ710722	752WSAA014	IF SHIELD CASE	
118	AE003022	723549A026	BADGE,BRAND	
119	AE003303	723549A032	AV LABEL	
120	AE003304	735WPAA637	BUTTON ASS'Y	
121	AE003305	735WPAA638	STOPPER,BUTTON 2	
122	BZ710723	752WSA0033	IF SHIELD BOTTOM	
123	AE003026	800WQ0A079	FELT SHEET	
124	AE003306	723000C488	SHEET,BAR CODE	
125	AE003028	791AHA0025	FILM BAG	
126	AE003029	792AHAA002	PACKAGE, TOP	
127	AE003030	792AHAA003	PACKAGE, BOTTOM	
128	AE003307	793ACDA180	GIFT BOX	
129	AE000218	795ACA0010	PAD	378x1114
130	AE003308	A3N116E975	INSTRUCTION BOOK KIT	
131	AD300882	JA4LD200	POLYBAG,INSTRUCTION(REDCAUTION)	
132	AE003033	J3K10517B	REGISTRATION CARD	
133	AE003309	J3N11601A	INSTRUCTION BOOK	
201	AE003036	8141J60D54	SCREW,TAP TITE(P) GW18	6x45
202	BZ710035	8117540A64	SCREW,TAPPING(B0) TRUSS	4x16
203	BZ710031	8110630A04	SCREW,TAP TITE(P) BRAZIER	3x10
204	BZ710239	8109I30A04	SCREW,TAP TITE(B) WH7	3x10
205	BZ710019	8109630802	SCREW,TAP TITE(B) BRAZIER	3x8
206	BZ710018	8107630804	SCREW,TAP TITE(S) BRAZIER	3x8
207	BZ710030	8110630804	SCREW,TAP TITE(P) BRAZIER	3x8
208	BZ710036	8117540B04	SCREW,TAPPING(B0) TRUSS	4x20

ELECTRICAL REPLACEMENT PARTS LIST

Location No.	TSB P/N	Reference No.	Description
RESISTORS			
△R410	AD300783	R3X181221J	R,METAL OXIDE 220 OHM 1W
△R416	BZ210053	R002T22R2J	RC 2.2 OHM 1/2W
△R420	AD301345	R002T22R7J	RC 2.7 OHM 1/2W
△R426	AE000913	R4X5T6682F	R,METAL 6.8K OHM 1/6W
R434	AD301972	R5X2CF5R6J	R,CEMENT 5.6 OHM 10W
△R436	AD301594	R4X5T6473F	R,METAL 47K OHM 1/6W
△R438	BZ210079	R6558A4R7J	R,FUSE 4.7 OHM 2W
△R439	AE000676	R3K181102J	R,METAL 1K OHM 1W
△R444	AD302347	R3X181120J	R,METAL OXIDE 12 OHM 1W
△R445	AD302347	R3X181120J	R,METAL OXIDE 12 OHM 1W
△R452	AD302348	R3X18A102J	R,METAL OXIDE 1K OHM 2W
△R455	AD302349	R65582101J	R,FUSE 100 OHM 1/2W
△R459	AD301595	R65582010J	R,FUSE 1 OHM 1/2W
R460	BZ210021	R65582680J	R,FUSE 68 OHM 1/2W
△R500	BZ210080	R0G3K2275K	RC 2.7M OHM 1/2W
△R501	AD300035	R5X2CE010J	R,CEMENT 1 OHM 7W
△R502	AD301016	R3X28A331J	R,METAL OXIDE 330 OHM 2W
△R503	AD302351	R3X181R56J	R,METAL OXIDE 0.56 OHM 1W
△R506	BZ210166	R002T4562J	RC 5.6K OHM 1/4W
△R517	AD301973	R3X28BR22J	R,METAL 0.22 OHM 3W
△R520	BZ210206	R002T2155J	RC 1.5M OHM 1/2W
△R527	BZ210149	R3X18AR68J	R,METAL OXIDE 0.68 OHM 2W
△R541	BZ210190	R63581R22J	R,FUSE 0.22 OHM 1W
△R542	AD302351	R3X181R56J	R,METAL OXIDE 0.56 OHM 1W
△R602	AD302352	R3X28B150J	R,METAL OXIDE 15 OHM 3W
△R643	BZ210028	R3X28B6R8J	R,METAL OXIDE 6.8 OHM 3W
△R644	BZ210028	R3X28B6R8J	R,METAL OXIDE 6.8 OHM 3W
△R804	BZ210050	R3X18A123J	R,METAL OXIDE 12K OHM 2W
△R806	BZ210050	R3X18A123J	R,METAL OXIDE 12K OHM 2W
△R808	BZ210050	R3X18A123J	R,METAL OXIDE 12K OHM 2W
△R855	BZ210185	R65582151J	R,FUSE 150 OHM 1/2W
△R881	AD300417	R3X18A560J	R,METAL OXIDE 56 OHM 2W
CAPACITORS			
△C408	BZ210176	E02LF3222M	CE 2200 UF 25V
△C412	AE000911	P4N8FK222H	CMPP 0.0022UF 1.5KV
△C413	AD300066	E02LF4222M	CE 2200 UF 35V
△C418	AE001019	P4J7F3434J	CMPP 0.43 UF 250V PMS
△C420	AD301978	P4N8FJ133H	CMPP 0.013 UF 1.25KV
△C421	AD300048	P3N1F5183J	CPP 0.018 UF 630V
C425	BZ110202	C0PLRR713K	CC 0.001 UF 2KV R
△C426	BZ110204	E0ELFD220M	CE 22 UF 250V
△C430	BZ110195	E02LU8220M	CE 22 UF 100V
C442	AD301601	E53FF56R8M	CE 6.8 UF 50V NP
△C501	AD300066	E02LF4222M	CE 2200 UF 35V
△C502	BZ110202	C0PLRR713K	CC 0.001 UF 2KV R
△C503	BZ110202	C0PLRR713K	CC 0.001 UF 2KV R
△C504	AD301348	E02LU5100M	CE 10 UF 50V
△C505	BZ110025	P2122B224M	CMP 0.22 UF 275V ECQUL
△C506	BZ110035	P2122B104M	CMP 0.1 UF 275V ECQUL
△C507	AE000700	E52DHC681M	CE 680 UF 200V
△C508	AD301108	CD39E0MH3M	CC 0.0022UF 250V
△C513	AD301026	CD39E0M13M	CC 0.001 UF 250V
C517	BZ110202	C0PLRR713K	CC 0.001 UF 2KV R
△C519	AD301026	CD39E0M13M	CC 0.001 UF 250V
△C521	AD301025	E62NFB221M	CE 220 UF 160V
△C527	AD300925	E02LT2102M	CE 1000 UF 16V
C535	BZ110191	C03LOR7E3K	CC 0.0015UF 2KV R
C537	BZ110076	E02LF1222M	CE 2200 UF 10V
C808	BZ110226	C0JBB07H3K	CC 0.0022UF 2KV B
C1003	AD300067	E02LF4102M	CE 1000 UF 35V
C1004	BZ110053	E02LF3102M	CE 1000 UF 25V
C1009	BZ110053	E02LF3102M	CE 1000 UF 25V
DIODES			
D001	BZ410019	D97U03001B	DIODE,ZENER MTZJ30B T-77
D102	BZ410006	D1VT001330	DIODE,SILICON 1SS133T-77
D103	BZ410006	D1VT001330	DIODE,SILICON 1SS133T-77
D104	BZ410006	D1VT001330	DIODE,SILICON 1SS133T-77
D105	BZ410006	D1VT001330	DIODE,SILICON 1SS133T-77
D106	BZ410020	D97U05R11B	DIODE,ZENER MTZJ5.1B T-77
D107	BZ410006	D1VT001330	DIODE,SILICON 1SS133T-77
D108	BZ410006	D1VT001330	DIODE,SILICON 1SS133T-77

ELECTRICAL REPLACEMENT PARTS LIST

Location No.	TSB P/N	Reference No.	Description
		DIODES	
D109	BZ410054	0021721150	LED
D111	BZ410021	D97U05R61B	DIODE,ZENER
D401	AD300670	D97U01501B	DIODE,ZENER
D402	BZ410043	D2WT011E10	DIODE,SILICON
D403	BZ410019	D97U03001B	DIODE,ZENER
D404	BZ410020	D97U05R11B	DIODE,ZENER
△D405	BZ410063	D2WTAU02A0	DIODE,SILICON
△D406	BZ410021	D97U05R61B	DIODE,ZENER
△D407	BZ410063	D2WTAU02A0	DIODE,SILICON
△D408	AD302110	D2CF0715L0	DIODE,SILICON
△D409	AD301980	D2CF2016L0	DIODE,SILICON
D410	BZ410019	D97U03001B	DIODE,ZENER
△D411	BZ410063	D2WTAU02A0	DIODE,SILICON
D412	AD300670	D97U01501B	DIODE,ZENER
D413	BZ410006	D1VT001330	DIODE,SILICON
D414	BZ410043	D2WT011E10	DIODE,SILICON
D415	BZ410043	D2WT011E10	DIODE,SILICON
D416	BZ410043	D2WT011E10	DIODE,SILICON
D417	AD300070	D97U01201B	DIODE,ZENER
D418	BZ410006	D1VT001330	DIODE,SILICON
△D501	BZ410062	D2WTRM11C0	DIODE,SILICON
△D502	BZ410062	D2WTRM11C0	DIODE,SILICON
△D503	BZ410062	D2WTRM11C0	DIODE,SILICON
△D504	BZ410062	D2WTRM11C0	DIODE,SILICON
△D505	AD300076	D28F30DF60	DIODE,RECTIFIER
△D506	AD300731	D2WXN49370	DIODE,SILICON
D507	BZ410006	D1VT001330	DIODE,SILICON
D508	BZ410006	D1VT001330	DIODE,SILICON
D509	AD300671	D97U01801B	DIODE,ZENER
△D510	AD301980	D2CF2016L0	DIODE,SILICON
△D511	AD300731	D2WXN49370	DIODE,SILICON
△D512	BZ410010	D28T21DQN9	DIODE,SCHOTTKY
D513	BZ410006	D1VT001330	DIODE,SILICON
D514	BZ410061	D97U01001B	DIODE,ZENER
D515	BZ410008	D23U1003A3	DIODE,SCHOTTKY
D516	BZ410006	D1VT001330	DIODE,SILICON
D517	BZ410006	D1VT001330	DIODE,SILICON
D518	BZ410010	D28T21DQN9	DIODE,SCHOTTKY
△D519	BZ410010	D28T21DQN9	DIODE,SCHOTTKY
D520	BZ410006	D1VT001330	DIODE,SILICON
D522	BZ410006	D1VT001330	DIODE,SILICON
△D523	AD300671	D97U01801B	DIODE,ZENER
D524	BZ410006	D1VT001330	DIODE,SILICON
D525	BZ410064	D97U03R91B	DIODE,ZENER
D526	BZ410006	D1VT001330	DIODE,SILICON
D527	BZ410067	D97U02R21B	DIODE,ZENER
D528	BZ410021	D97U05R61B	DIODE,ZENER
D529	BZ410006	D1VT001330	DIODE,SILICON
D531	AD300070	D97U01201B	DIODE,ZENER
D532	BZ410006	D1VT001330	DIODE,SILICON
△D533	AD300731	D2WXN49370	DIODE,SILICON
D601	BZ410006	D1VT001330	DIODE,SILICON
D602	BZ410058	D97U08R21B	DIODE,ZENER
D604	AD300070	D97U01201B	DIODE,ZENER
D605	BZ410006	D1VT001330	DIODE,SILICON
D606	BZ410006	D1VT001330	DIODE,SILICON
D607	BZ410006	D1VT001330	DIODE,SILICON
D608	BZ410043	D2WT011E10	DIODE,SILICON
D701	BZ410066	D97U06R21B	DIODE,ZENER
D702	AD300070	D97U01201B	DIODE,ZENER
D703	AD300070	D97U01201B	DIODE,ZENER
D704	AD300070	D97U01201B	DIODE,ZENER
D705	BZ410006	D1VT001330	DIODE,SILICON
D706	BZ410006	D1VT001330	DIODE,SILICON
D709	BZ410066	D97U06R21B	DIODE,ZENER
D710	BZ410006	D1VT001330	DIODE,SILICON
D801	BZ410006	D1VT001330	DIODE,SILICON
D802	BZ410006	D1VT001330	DIODE,SILICON
D803	BZ410006	D1VT001330	DIODE,SILICON
D804	BZ410006	D1VT001330	DIODE,SILICON
D805	BZ410006	D1VT001330	DIODE,SILICON

ELECTRICAL REPLACEMENT PARTS LIST

Location No.	TSB P/N	Reference No.	Description
DIODES			
D806	BZ410006	D1VT001330	DIODE,SILICON
D807	BZ410006	D1VT001330	DIODE,SILICON
D808	BZ410006	D1VT001330	DIODE,SILICON
D809	BZ410006	D1VT001330	DIODE,SILICON
D852	BZ410006	D1VT001330	DIODE,SILICON
D853	BZ410006	D1VT001330	DIODE,SILICON
D854	BZ410006	D1VT001330	DIODE,SILICON
D855	BZ410006	D1VT001330	DIODE,SILICON
D856	BZ410006	D1VT001330	DIODE,SILICON
D857	BZ410011	D28TELS2N2	DIODE,RECTIFER
D858	BZ410011	D28TELS2N2	DIODE,RECTIFER
ICS			
IC101	AD302354	I56F07092A	IC
IC199	AE003310	A3N116E015	INIT DATA
IC301	AD300055	I0QF021500	IC
IC302	AD301983	I01FF58910	IC
△IC401	AD300414	I03TD80410	IC
△IC402	AD302356	I03S065100	IC
△IC501	AD301770	I07E00358F	IC
△IC504	AD301771	000220001W	PHOTO COUPLER
IC601	AE002803	I06FC1283A	IC
IC701	AE002728	I01F05853B	IC
IC902	AD300059	I01FF58290	IC
△IC1001	AD300056	I0FSP52760	IC
IC1503	AE003311	I55FE65FG0	IC
TRANSISTORS			
Q101	BZ510109	TCAA3875SY	TRANSISTOR,SILICON
Q103	BZ510109	TCAA3875SY	TRANSISTOR,SILICON
Q401	BZ510109	TCAA3875SY	TRANSISTOR,SILICON
△Q402	BZ510097	TCAT03227Y	TRANSISTOR,SILICON
△Q405	AD302136	TD50026380	TRANSISTOR,SILICON
Q408	BZ510073	TAATA12660	TRANSISTOR,SILICON
Q409	BZ510073	TAATA12660	TRANSISTOR,SILICON
Q410	AD300027	TC30041590	TRANSISTOR,SILICON
△Q502	BZ510098	T220033260	FET
△Q503	BZ510005	TA3T1371A0	TRANSISTOR,SILICON
Q504	BZ510069	TCATC31980	TRANSISTOR,SILICON
△Q505	BZ510011	TC3T029090	TRANSISTOR,SILICON
Q506	BZ510071	TNAAB05003	COMPOUND TRANSISTOR
△Q507	BZ510069	TCATC31980	TRANSISTOR,SILICON
△Q508	AD300611	TAAT01273Y	TRANSISTOR,SILICON
△Q509	BZ510105	TCAT03209Y	TRANSISTOR,SILICON
Q510	BZ510108	TAAA1504SY	TRANSISTOR,SILICON
△Q511	AD300611	TAAT01273Y	TRANSISTOR,SILICON
△Q512	BZ510004	TA3T016240	TRANSISTOR,SILICON
△Q514	BZ510070	TCAT032034	TRANSISTOR,SILICON
Q515	BZ510071	TNAAB05003	COMPOUND TRANSISTOR
△Q516	BZ510105	TCAT03209Y	TRANSISTOR,SILICON
Q517	BZ510109	TCAA3875SY	TRANSISTOR,SILICON
Q518	BZ510109	TCAA3875SY	TRANSISTOR,SILICON
△Q519	BZ510105	TCAT03209Y	TRANSISTOR,SILICON
Q601	BZ510105	TCAT03209Y	TRANSISTOR,SILICON
Q602	BZ510105	TCAT03209Y	TRANSISTOR,SILICON
Q603	BZ510109	TCAA3875SY	TRANSISTOR,SILICON
Q604	BZ510105	TCAT03209Y	TRANSISTOR,SILICON
Q605	BZ510109	TCAA3875SY	TRANSISTOR,SILICON
Q606	BZ510105	TCAT03209Y	TRANSISTOR,SILICON
Q607	BZ510070	TCAT032034	TRANSISTOR,SILICON
Q608	BZ510109	TCAA3875SY	TRANSISTOR,SILICON
Q611	BZ510105	TCAT03209Y	TRANSISTOR,SILICON
Q701	BZ510109	TCAA3875SY	TRANSISTOR,SILICON
Q702	BZ510109	TCAA3875SY	TRANSISTOR,SILICON
Q703	BZ510109	TCAA3875SY	TRANSISTOR,SILICON
Q709	BZ510108	TAAA1504SY	TRANSISTOR,SILICON
Q711	BZ510109	TCAA3875SY	TRANSISTOR,SILICON
Q712	BZ510109	TCAA3875SY	TRANSISTOR,SILICON
△Q801	BZ510091	TCA0042170	TRANSISTOR,SILICON
△Q802	BZ510091	TCA0042170	TRANSISTOR,SILICON
△Q803	BZ510091	TCA0042170	TRANSISTOR,SILICON
△Q810	AD301032	TCATC3199Y	TRANSISTOR,SILICON
△Q811	AD301032	TCATC3199Y	TRANSISTOR,SILICON

ELECTRICAL REPLACEMENT PARTS LIST

Location No.	TSB P/N	Reference No.	Description
TRANSISTORS			
△Q812	AD301032	TCATC3199Y	TRANSISTOR,SILICON
Q852	BZ510069	TCATC31980	TRANSISTOR,SILICON
Q853	AD300024	TCUT00752Y	TRANSISTOR,SILICON
Q854	BZ510069	TCATC31980	TRANSISTOR,SILICON
Q855	BZ510069	TCATC31980	TRANSISTOR,SILICON
Q856	BZ510069	TCATC31980	TRANSISTOR,SILICON
Q857	BZ510073	TAATA12660	TRANSISTOR,SILICON
Q858	AD300029	TAU0018370	TRANSISTOR,SILICON
Q859	AD300025	TCU0047930	TRANSISTOR,SILICON
Q901	BZ510108	TAAA1504SY	TRANSISTOR,SILICON
Q902	BZ510108	TAAA1504SY	TRANSISTOR,SILICON
Q1001	BZ510068	TNAAJ05003	COMPOUND TRANSISTOR
Q1503	BZ510109	TCAA3875SY	TRANSISTOR,SILICON
Q1504	BZ510109	TCAA3875SY	TRANSISTOR,SILICON
Q1505	BZ510108	TAAA1504SY	TRANSISTOR,SILICON
Q1506	BZ510108	TAAA1504SY	TRANSISTOR,SILICON
Q1507	BZ510109	TCAA3875SY	TRANSISTOR,SILICON
Q1508	BZ510109	TCAA3875SY	TRANSISTOR,SILICON
Q1509	BZ510108	TAAA1504SY	TRANSISTOR,SILICON
Q1510	BZ510109	TCAA3875SY	TRANSISTOR,SILICON
Q1511	BZ510108	TAAA1504SY	TRANSISTOR,SILICON
Q1512	BZ510109	TCAA3875SY	TRANSISTOR,SILICON
Q1513	BZ510109	TCAA3875SY	TRANSISTOR,SILICON
Q1514	BZ510108	TAAA1504SY	TRANSISTOR,SILICON
Q1515	BZ510108	TAAA1504SY	TRANSISTOR,SILICON
COILS & TRANSFORMERS			
L301	BZ310039	02167F220J	COIL
L401	AD302359	02ER000001	COIL
L402	AD300400	022100034A	COIL,LINEARITY
L403	AD301606	02DK000058	COIL,CHOKE
L404	BZ310004	021679472K	COIL
△L501	AD301124	029T000101	COIL,LINE FILTER
L503	AE003003	028R270013	COIL,DEGAUSS
L601	AD301989	0216A6330J	COIL
L701	BZ310040	02167F470J	COIL
L702	BZ310040	02167F470J	COIL
L802	AD300123	021673151K	COIL
L803	AD300123	021673151K	COIL
L804	AD300123	021673151K	COIL
L901	BZ310039	02167F220J	COIL
L1501	AD300613	02167F150J	COIL
L1502	AD302362	02167F270J	COIL
L1503	AD302362	02167F270J	COIL
L1504	BZ310039	02167F220J	COIL
L1505	BZ310039	02167F220J	COIL
L1506	BZ310039	02167F220J	COIL
L1507	BZ310039	02167F220J	COIL
L1508	BZ310039	02167F220J	COIL
L1509	BZ310039	02167F220J	COIL
L1510	BZ310039	02167F220J	COIL
T401	AD301125	0450190161	TRANS,HORIZONTAL DRIVE
△T501	AD302363	048140068S	TRANSFORMER,SWITCHING
JACKS			
J701	AD301038	060J431019	RCA JACK
J702	AD300108	063Q700002	JACK
J703	AD301038	060J431019	RCA JACK
J704	AD301037	060J411024	RCA JACK
J705	AD300110	060G401047	RCA JACK
J706	AD300111	060G401046	RCA JACK
J707	AD300112	060G401039	RCA JACK
J708	AD301038	060J431019	RCA JACK
J709	AD300108	063Q700002	JACK
△J801	BZ614115	066C130017	SOCKET,CATHODE RAY TUBE
J1001	BZ614361	060J131015	HEADPHONE JACK
SWITCHES			
SW101	BZ612010	0504101T34	SWITCH,TACT
SW102	BZ612010	0504101T34	SWITCH,TACT
SW103	BZ612010	0504101T34	SWITCH,TACT
SW104	BZ612010	0504101T34	SWITCH,TACT
SW105	BZ612010	0504101T34	SWITCH,TACT

ELECTRICAL REPLACEMENT PARTS LIST

Location No.	TSB P/N	Reference No.	Description
VARIABLE RESISTORS			
VR401	BZ210108	V116313BTC	VOLUME,SEMI FIXED
VR502	BZ210101	V1163H4BTC	VOLUME,SEMI FIXED
P.C.BOARD ASSEMBLIES			
PCB010	AE003312	A3N116F010K	PCB ASS'Y
PCB060	AE003313	A3N116F060K	PCB ASS'Y
PCB110	AE003314	A3N116F110K	PCB ASS'Y
PCB330	AE003315	A3N116F330K	PCB ASS'Y
MISCELLANEOUS			
B401	BZ310129	024HT03564	CORE,BEADS
B403	BZ310122	024HT03563	CORE,BEADS
B502	BZ310045	024AT03481	CORE,BEADS
B503	BZ310121	024HT03553	CORE,BEADS
B504	BZ310121	024HT03553	CORE,BEADS
B851	BZ310121	024HT03553	CORE,BEADS
B852	BZ310121	024HT03553	CORE,BEADS
B853	BZ310121	024HT03553	CORE,BEADS
BT001	AD302369	141L003010	BATTERY,MANGAN
BT002	AD302369	141L003010	BATTERY,MANGAN
△CD501	AD300746	120R615901	CORD,AC BUSH
CD801	BZ614457	06CU253901	CORD,CONNECTOR
CD802	AD302370	06CU275101	CORD,CONNECTOR
CD803	AD300094	06CP83035A	CORD,CONNECTOR
CD851	AD302371	06CU244701	CORD,CONNECTOR
CD852	AD301043	06CU232001	CORD,CONNECTOR
CP101	BZ614102	0694270139	CONNECTOR PCB SIDE
△CP401	AD300095	069X460029	CONNECTOR PCB SIDE
CP403	BZ614365	069S120419	CONNECTOR PCB SIDE
△CP501	BZ614176	069S320419	CONNECTOR PCB SIDE
△CP502	AD300687	069S420110	CONNECTOR PCB SIDE
CP507	BZ614444	069D01001A	CONNECTOR PCB SIDE
CP508	BZ614444	069D01001A	CONNECTOR PCB SIDE
CP803	AD301996	069S330010	CONNECTOR PCB SIDE
CP804	BZ614058	069W010010	CONNECTOR PCB SIDE
CP852	BZ614350	069S230629	CONNECTOR PCB SIDE
CD1001	AD302372	06CU14A001	CORD,CONNECTOR
CP1001	AD301045	069S140419	CONNECTOR PCB SIDE
CP1501	AD302373	069J1C0260	CONNECTOR PCB SIDE
CP801A	BZ614276	067U005049	WIRE HOLDER
CP801B	AD300752	069S250629	CONNECTOR PCB SIDE
CP802A	AD301997	067U007029	WIRE HOLDER
CP802B	BZ614485	069S270629	CONNECTOR PCB SIDE
CP851A	BZ614334	067U004029	WIRE HOLDER
CP851B	AD301998	069S240629	CONNECTOR PCB SIDE
CP852B	BZ614349	067U003029	WIRE HOLDER
EL001	BZ614044	124120301A	EYE LET
EL002	BZ614043	124116281A	EYE LET
△F501	AD301046	081PC6R305	FUSE
△FB401	AD302315	043227012F	TRANSFORMER,FLYBACK
FH501	AE002634	06710T0009	HOLDER,FUSE
FH502	AE002634	06710T0009	HOLDER,FUSE
OS101	AD301048	0773071001	REMOTE RECEIVER
△RY501	AD300114	0560V20115	RELAY
△SP1001	BZ614381	070C546004	SPEAKER
△SP1002	BZ614381	070C546004	SPEAKER
△TH501	BZ410079	DF5EL3R0A0	DEGAUSS ELEMENT
TM101	AD302374	07650GR010	TRANSMITTER
△TU001	AE000273	0163300005	RF UNIT
△V801	AE003010	098T270904	CRT W/DY
X101	AD302002	100CT8R005	CRYSTAL
X602	AD302003	100CT3R505	CRYSTAL

ELECTRICAL REPLACEMENT PARTS LIST

RESISTOR

RC..... CARBON RESISTOR

CAPACITORS

CC..... CERAMIC CAPACITOR

CE..... ALUMI ELECTROLYTIC CAPACITOR

CP..... POLYESTER CAPACITOR

CPP..... POLYPROPYLENE CAPACITOR

CPL..... PLASTIC CAPACITOR

CMP..... METAL POLYESTER CAPACITOR

CMPL..... METAL PLASTIC CAPACITOR

CMPP..... METAL POLYPROPYLENE CAPACITOR

TOSHIBA CORPORATION

1-1, SHIBAURA 1-CHOME, MINATO-KU, TOKYO 105-8001, JAPAN